

bamia

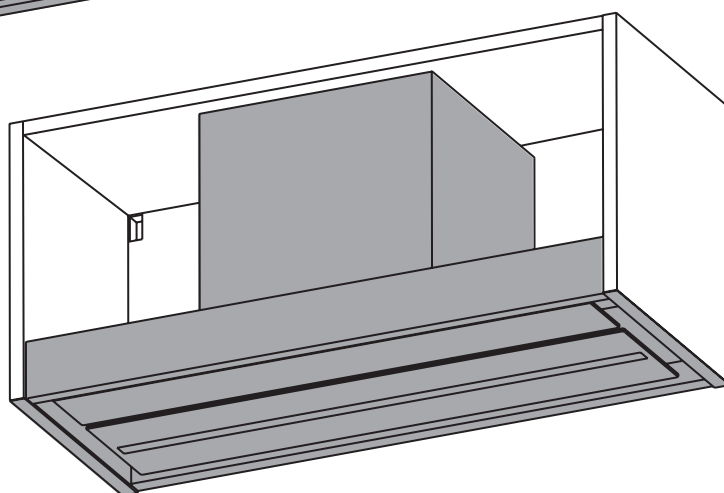

GHIH80 3663602434344

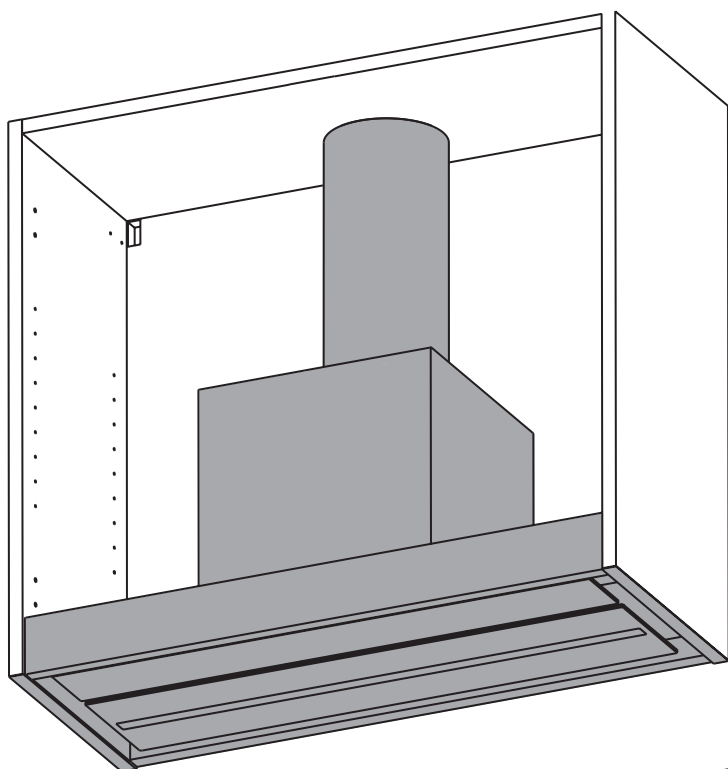

EN Contents
PL Zawartość

FR Contenu
RO Cuprins



Preparation

03

FR	Préparation	03
PL	Czynności wstępne	03
RO	Pregătire	03



Installation

04

FR	Installation	04
PL	Montaż	04
RO	Instalare	04



Use

36

FR	Utilisation	42
PL	Użytkowanie	50
RO	Utilizare	57



Care and Maintenance

64

FR	Entretien et maintenance	66
PL	Czyszczenie i konserwacja	68
RO	Îngrijire și întreținere	70



EN IMPORTANT - Please read carefully the separate safety guide before use.

FR IMPORTANT : veuillez lire attentivement le guide de sécurité avant utilisation.

PL WAŻNE – przed użyciem należy się uważnie zapoznać z dołączonymi oddzielnymi informacjami dotyczącymi bezpieczeństwa.

RO IMPORTANT - Citiți cu atenție ghidul separat privind siguranța înainte de utilizarea produsului.

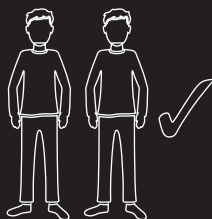

6mm

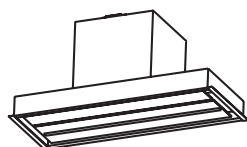

[01]x1

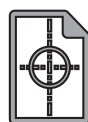

[02]x1

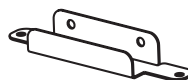

[03]x1



[04]x8
(3.5 x13mm)



[05]x2
(3.5 x9.5mm)

EN Not included

FR Non inclus

PL Brak w zestawie

RO Neinclus

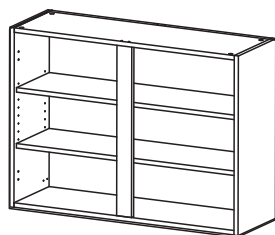

EN Standard Wall Cabinet 80cm x 72cm
Tall Wall Cabinet 80cm x 90cm

FR Armoire murale standard 80 cm x 72 cm
Grande armoire murale 80 cm x 90 cm

PL Standardowa szafka ścienna 80 cm x 72 cm
Wysoka szafka ścienna 80 cm x 90 cm

RO Dulap de perete standard 80 cm x 72 cm
Dulap de perete înalt 80 cm x 90 cm

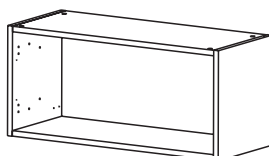

EN Bridging Wall Cabinet
80cm x 36cm

FR Armoire murale suspendue
80 cm x 36 cm

PL Łącznikowa szafka ścienna
80 cm x 36 cm

RO Dulap de perete de legătură
80 cm x 36 cm

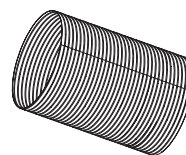

EN VENT PACK (Ø150mm)

FR PACK D'AÉRATION
(Ø150 mm)

PL ZESPÓŁ WENTYLACYJNY
(Ø150 cm)

RO SET AERISIRE (Ø 150 mm)

3663602843153

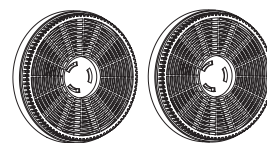

CARBFILT 50

3663602480051



01

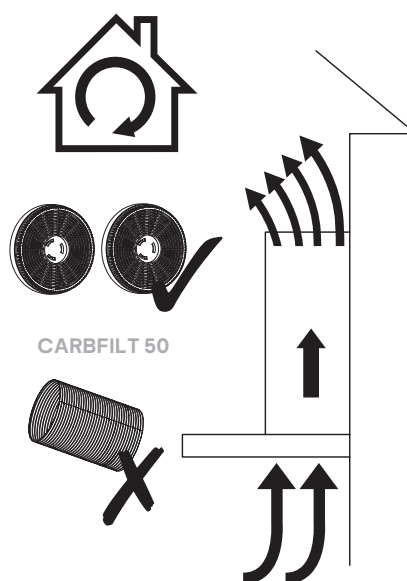
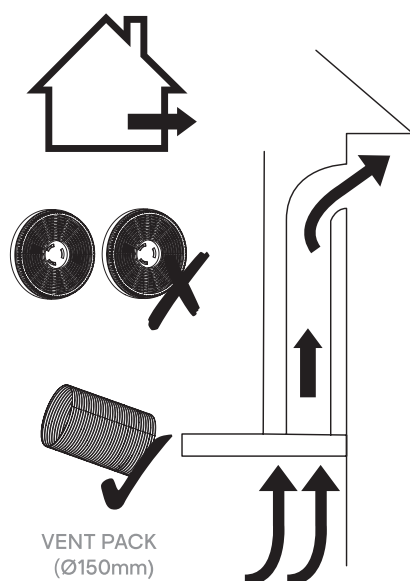

- EN** Choose a type of installation: Ducted option A (extraction to the outside) or Recirculation option B (no extraction to the outside). This appliance is for installation inside a wall cabinet or bridging cabinet only.
- FR** Choisir un type d'installation : option de conduit A (évacuation vers l'extérieur) ou option de recyclage B (pas d'évacuation vers l'extérieur). Cet électroménager convient pour une installation à l'intérieur d'une armoire murale ou d'une armoire suspendue uniquement.
- PL** Wybrać typ instalacji: opcja z kanałem A (wyciąg na zewnątrz) lub opcja recykulacyjna B (brak wyciągu na zewnątrz). Urządzenie to jest przeznaczone wyłącznie do instalacji wewnątrz szafki ściiennej lub szafki łącznikowej.
- RO** Alegeți un tip de instalare: Opțiunea cu tubatură A (evacuare în exterior) sau Opțiunea de recirculare B (fără evacuare în exterior). Acest aparat poate fi instalat numai într-un dulap de perete sau dulap de legătură.



02

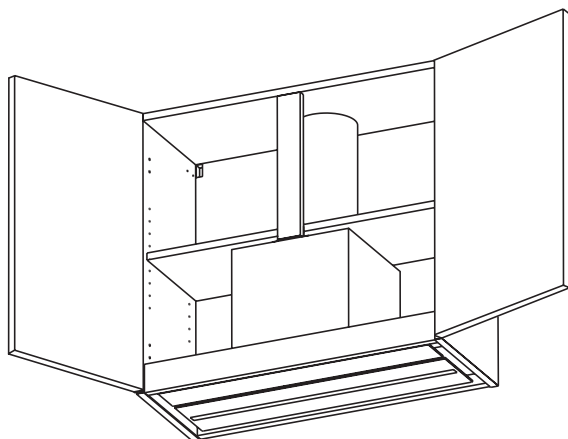

→ 04 - 25

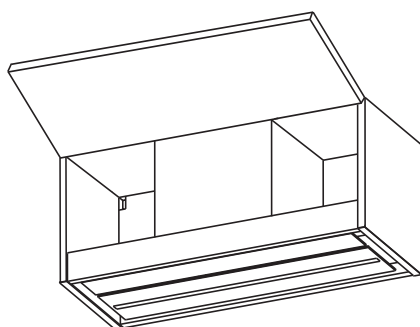
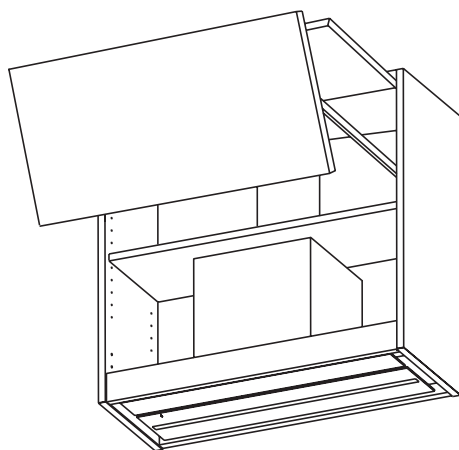

→ 26 - 41

EN **IMPORTANT:** You **MUST** ensure compliance with local building regulations regarding safe distances between your hob and the combustible materials of the cabinet when choosing one of the installation options above. Refer to section 03 of this instruction manual for guidance **BEFORE** you commence assembly.

FR **IMPORTANT :** vous **DEVEZ** assurer la conformité avec les réglementations locales en matière de construction concernant les distances de sécurité entre votre plaque de cuisson et les matériaux combustibles de l'armoire au moment de choisir l'une des options d'installation ci-dessus. Se reporter à la section 03 de cette notice pour obtenir des conseils **AVANT** de commencer l'assemblage.

PL **WAŻNE:** Wybierając jedną z powyższych opcji instalacji, **NALEŻY** zapewnić zgodność z lokalnymi przepisami budowlanymi dotyczącymi bezpiecznej odległości pomiędzy płytą grzewczą a materiałami łatwopalnymi. Ze wskazówkami znajdującymi się w części 03 niniejszej instrukcji obsługi należy zapoznać się **PRZED** rozpoczęciem montażu.

RO **IMPORTANT:** **TREBUIE** să asigurați respectarea reglementărilor locale în construcții referitoare la distanțele de siguranță dintre plită și materiale inflamabile ale dulapului, atunci când alegeți una dintre opțiunile de instalare de mai sus. Consultați secțiunea 03 a acestui manual de instrucțiuni pentru îndrumare **ÎNAINTE** de a începe asamblarea.



03

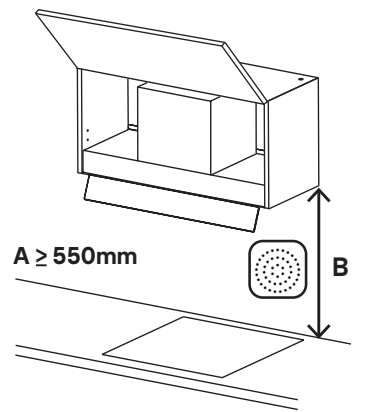
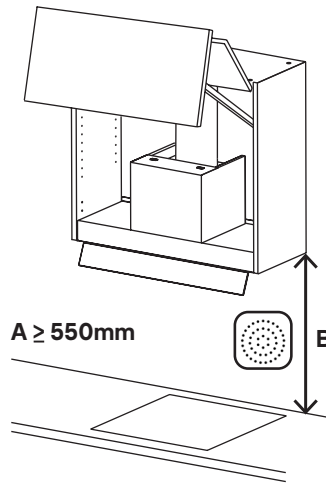
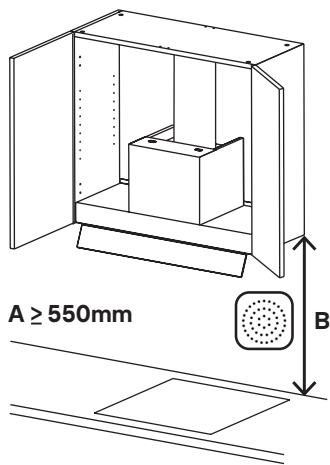
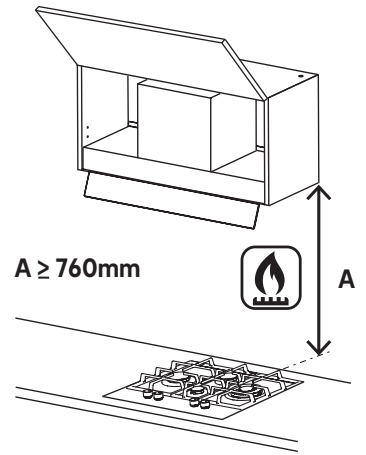
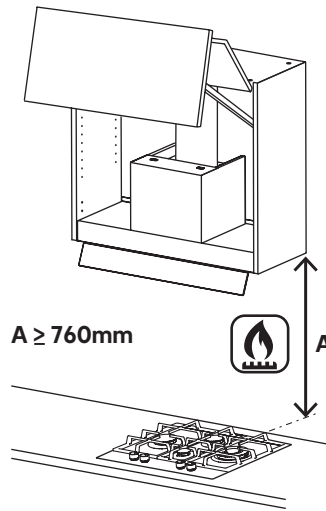
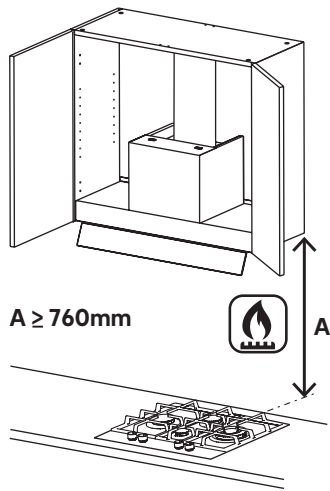

EN Use the cabinet instruction manual for guidance on wall installation.

FR Consulter la notice de l'armoire pour obtenir des conseils sur l'installation murale.

PL Aby uzyskać wskazówki dotyczące montażu na ścianie, skorzystaj z instrukcji obsługi szafki.

RO Utilizați manualul de instrucțiuni al dulapului pentru îndrumare privind instalarea pe perete.



04

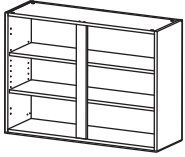

EN Standard Wall Cabinet
80cm x 72cm
Tall Wall Cabinet
80cm x 90cm

FR Armoire murale
standard 80 cm x 72 cm
Grande armoire murale
80 cm x 90 cm

PL Standardowa szafka
ścienna 80 cm x 72 cm
Wysoka szafka ścienna
80 cm x 90 cm

RO Dulap de perete
standard 80 cm x 72 cm
Dulap de perete înalt
80 cm x 90 cm

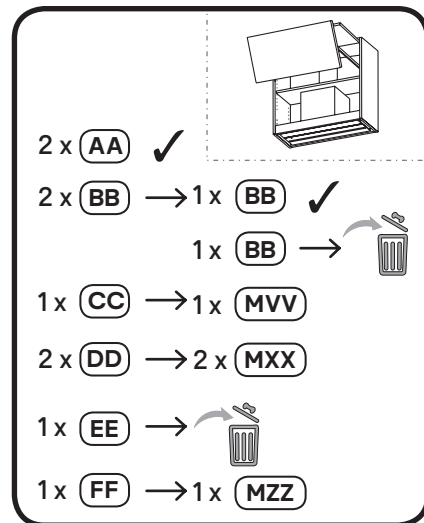
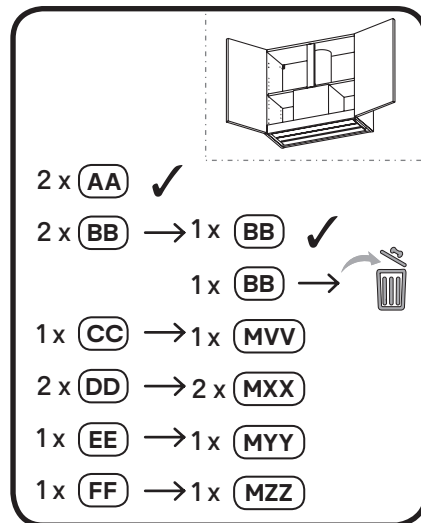
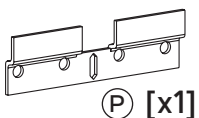
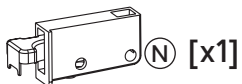
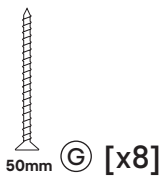
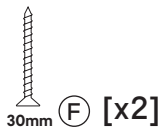
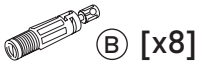
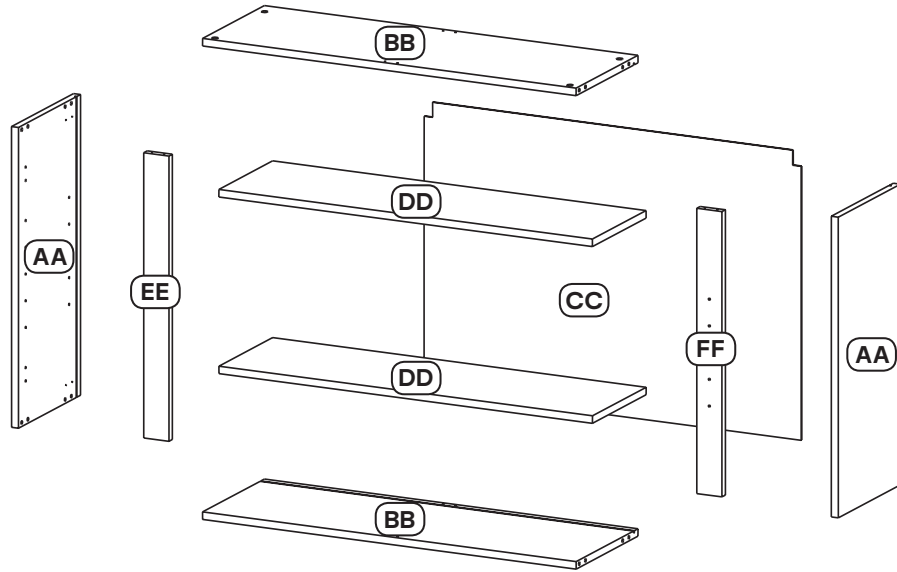

EN Identify the parts in your cabinet that require modification to allow installation of the appliance.
Do not dispose of the surplus parts until installation is complete!

FR Identifier les pièces de votre armoire à modifier pour permettre l'installation de l'électroménager.
Ne pas jeter les pièces en trop avant la fin de l'installation !

PL Należy zidentyfikować części w szafce, które wymagają modyfikacji w celu umożliwienia instalacji urządzenia.
Nie należy usuwać części nadmiarowych przed zakończeniem instalacji!

RO Identificați elementele dulapului care necesită modificare pentru a permite instalarea aparatului.
Nu aruncați elementele în plus înainte de finalizarea instalării!



05

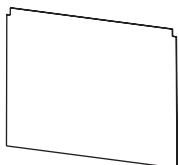
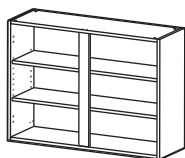

CC x1

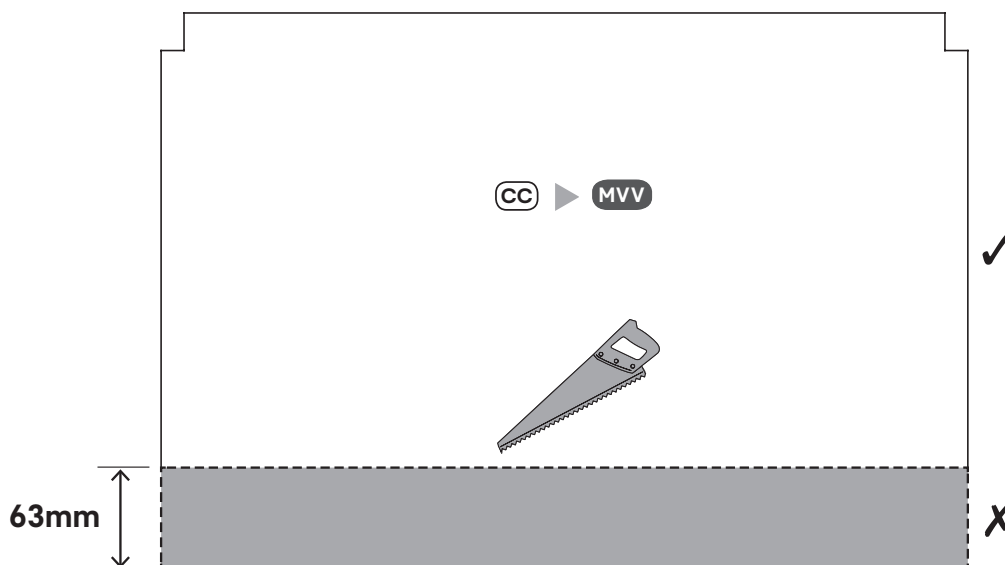
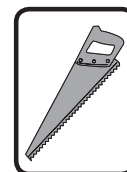

06



DD x2

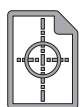

[H2] x1

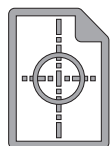

[H2]

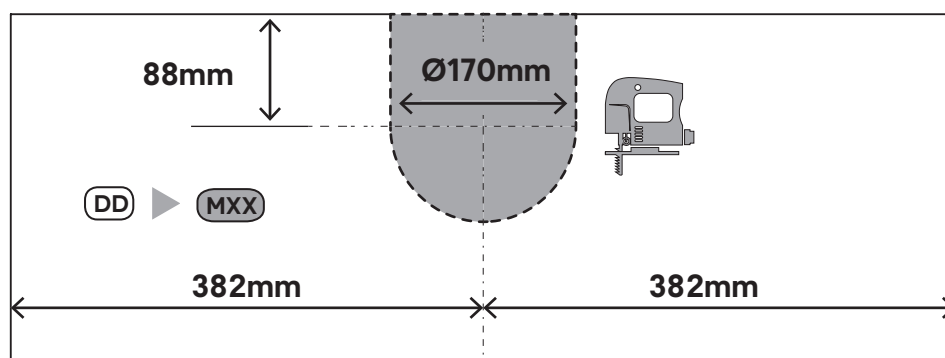
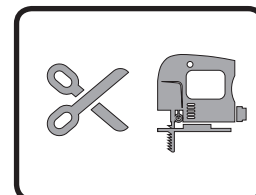

EN Using template [H2] mark (DD) and cut out using a jigsaw.

FR Utiliser le repère (DD) du modèle [H2] et découper à l'aide d'une scie sauteuse.

PL Używając szablonu [H2] oznacz (DD) i wytnij wyrzynarką.

RO Utilizați șablonul [H2] marcajul (DD) și tăiați cu ajutorul unui ferăstrău.

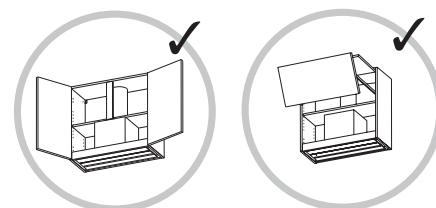



07



EE x1

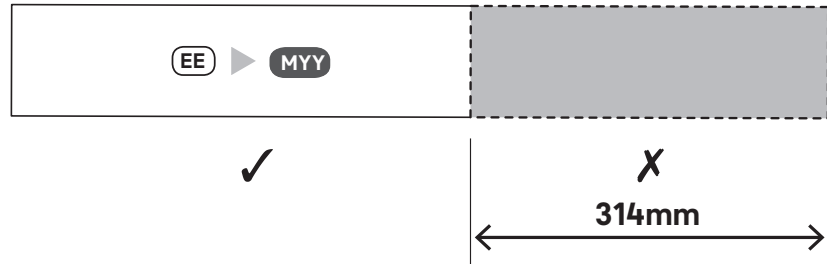
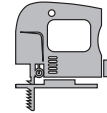
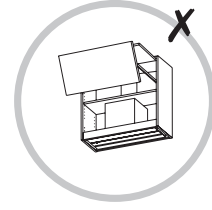
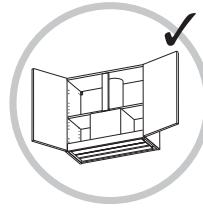
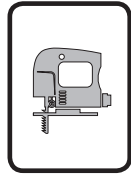

08



FF x1

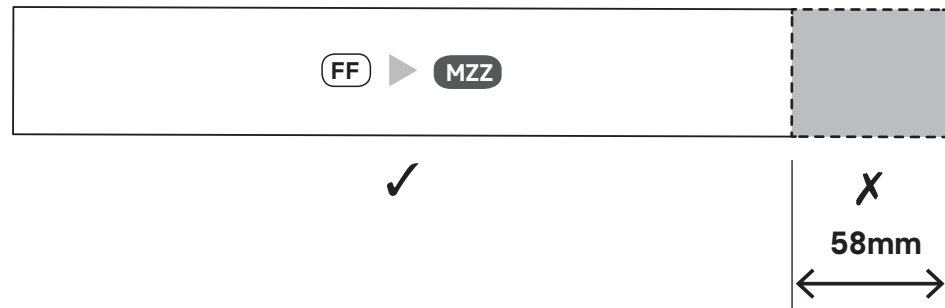
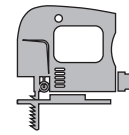
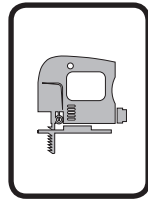

09

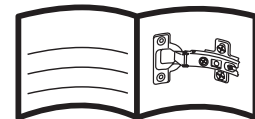
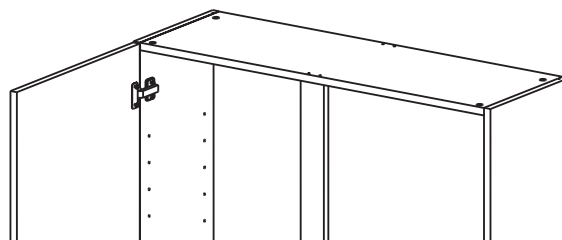





10

(A)  x8

(B)  x8

(C)  x8

 (BB) x1

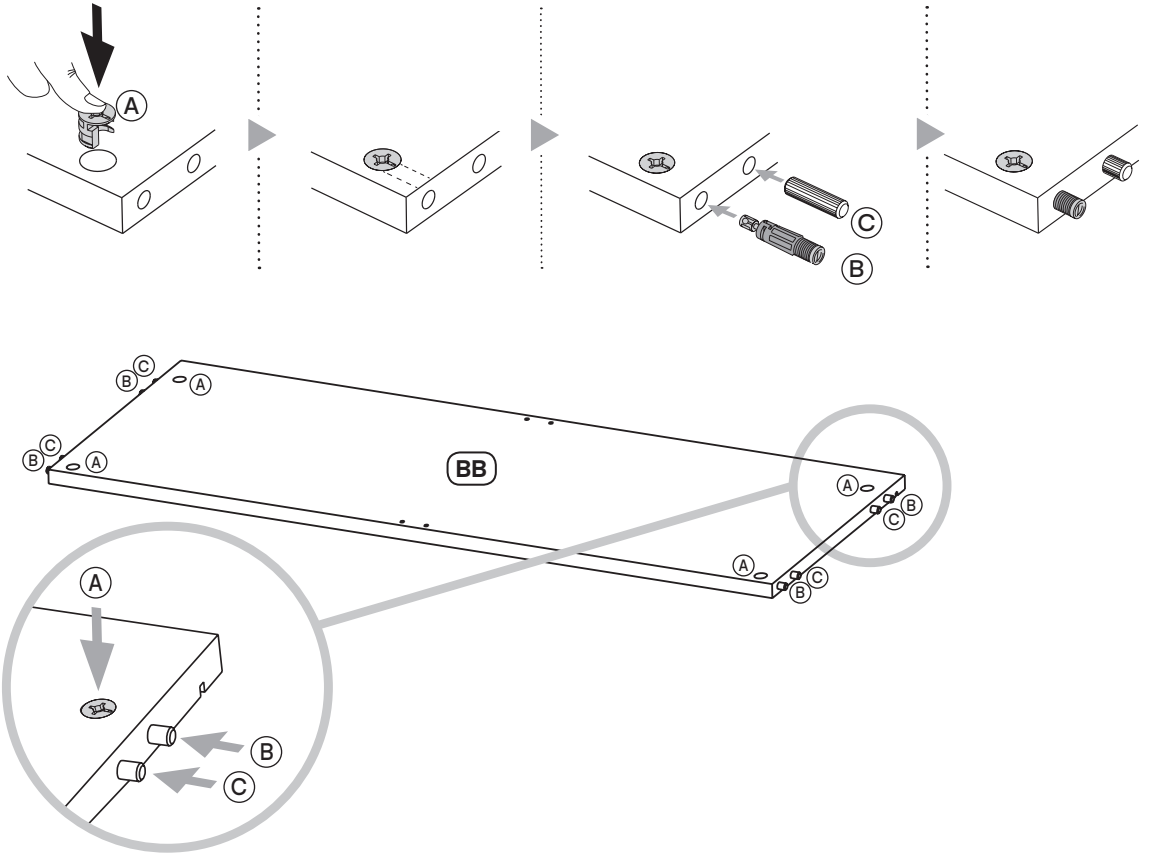

11

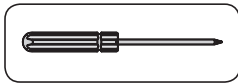

(AL)  16mm x4

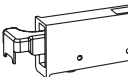
(M)  x1

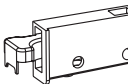
(N)  x1

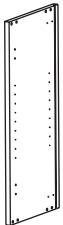

(AA) x2

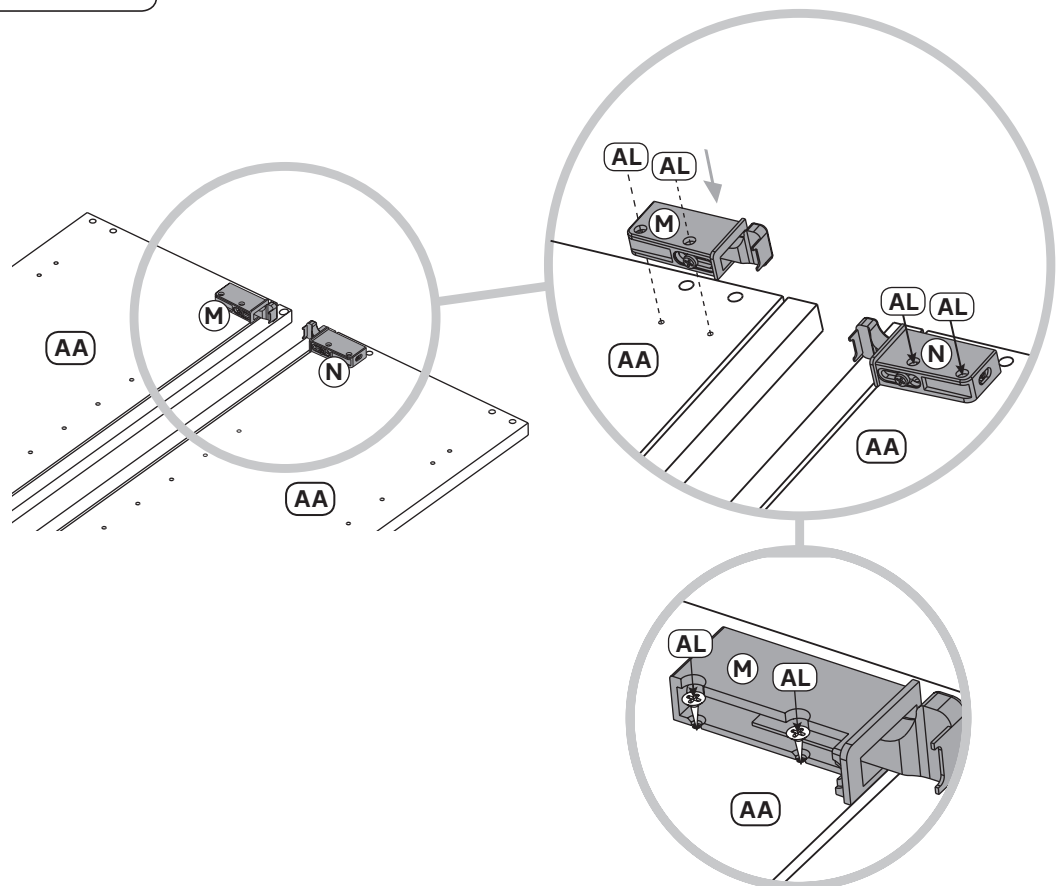



12

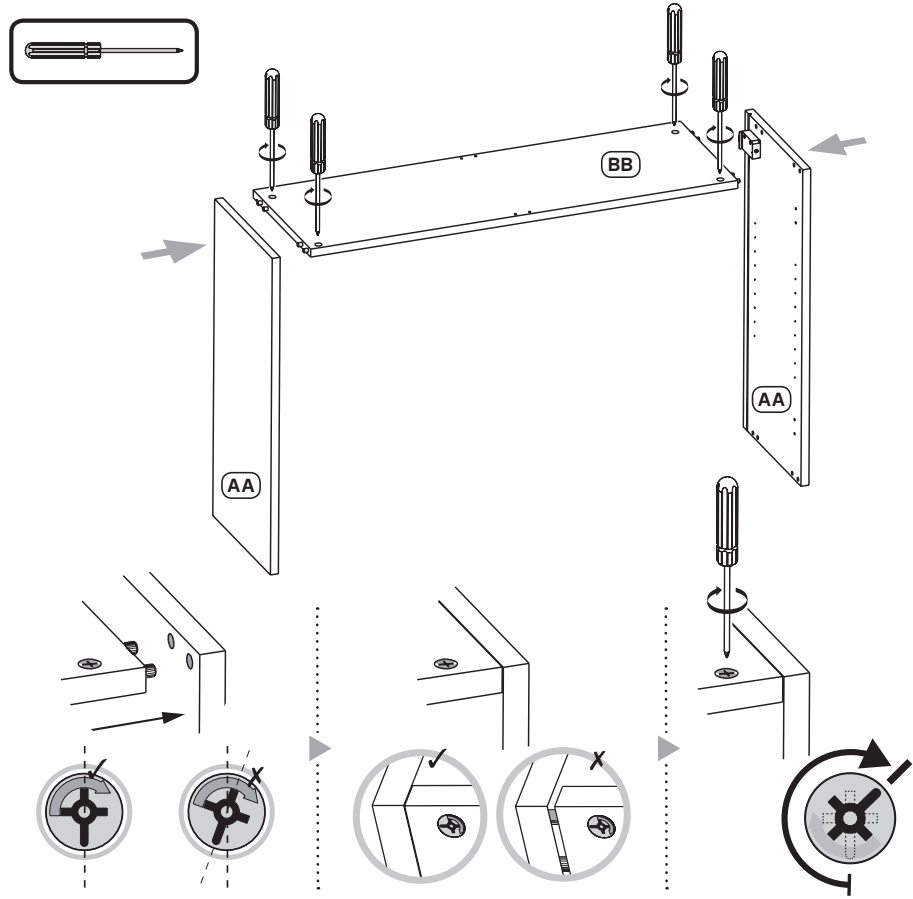
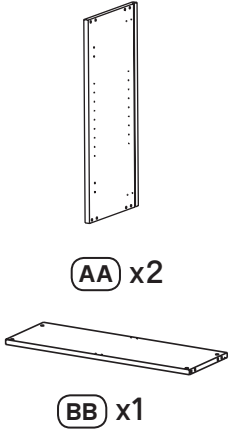

13

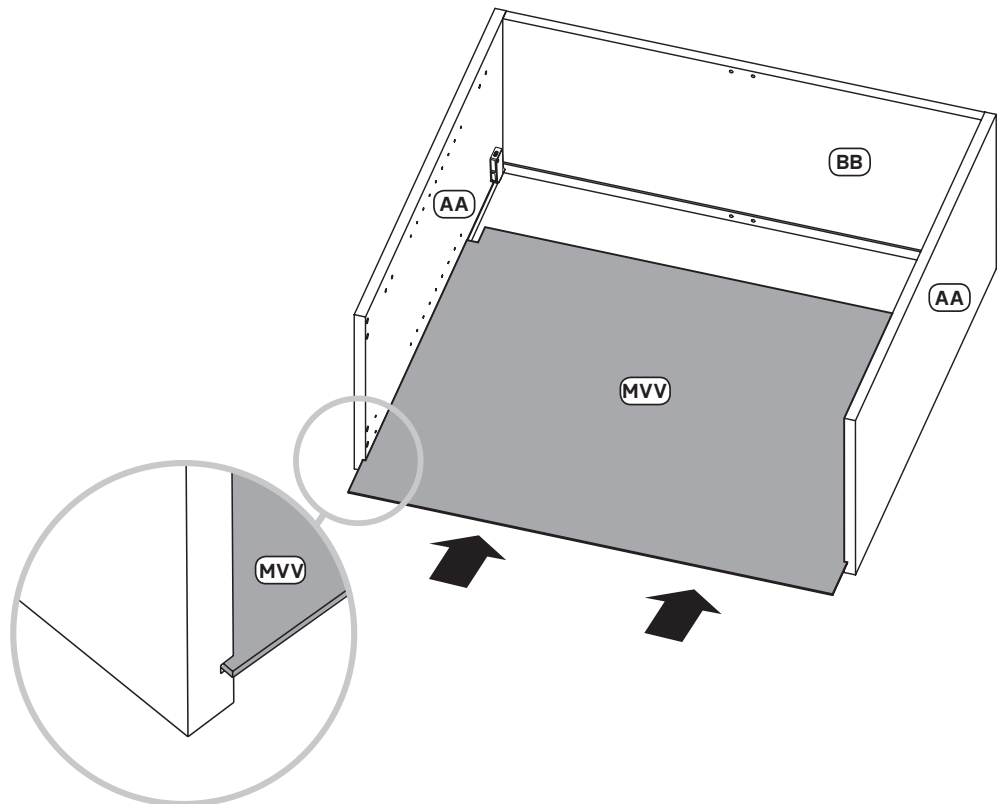
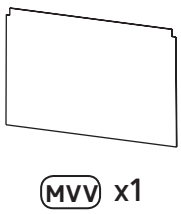



14

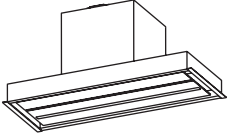

[01]x1

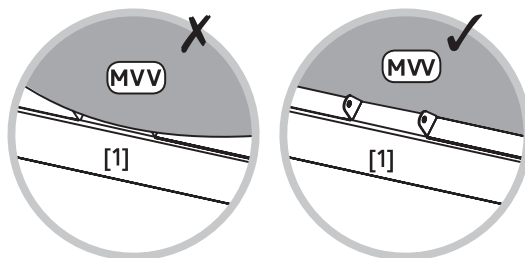
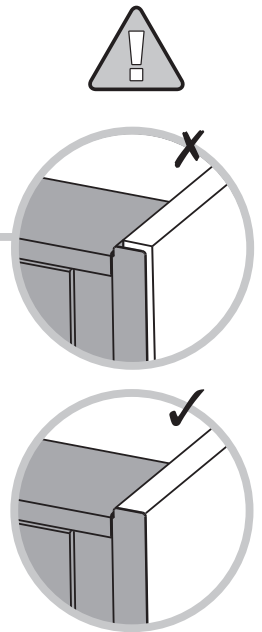
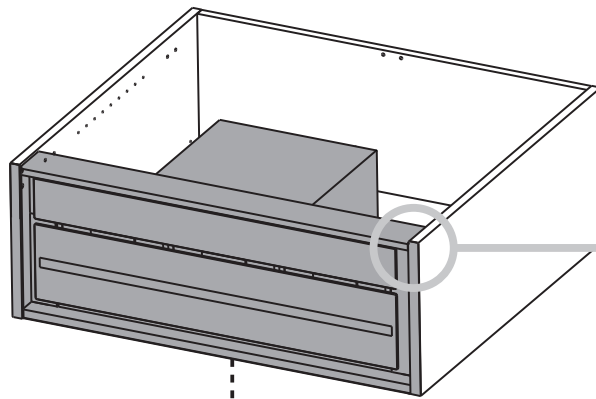
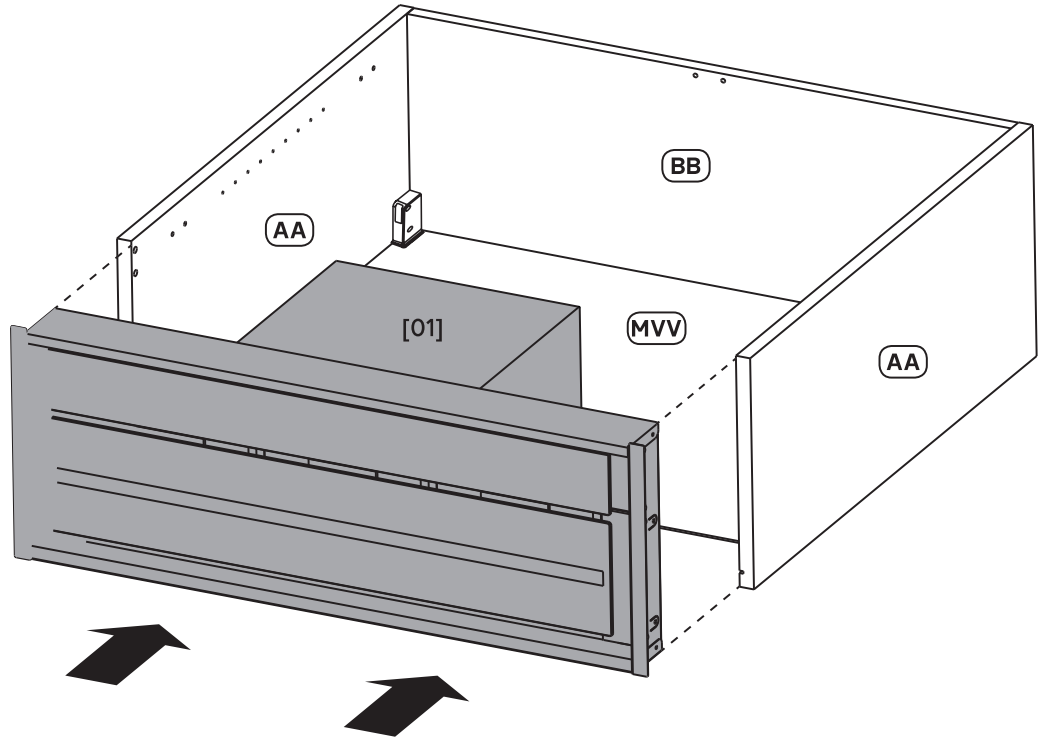



15

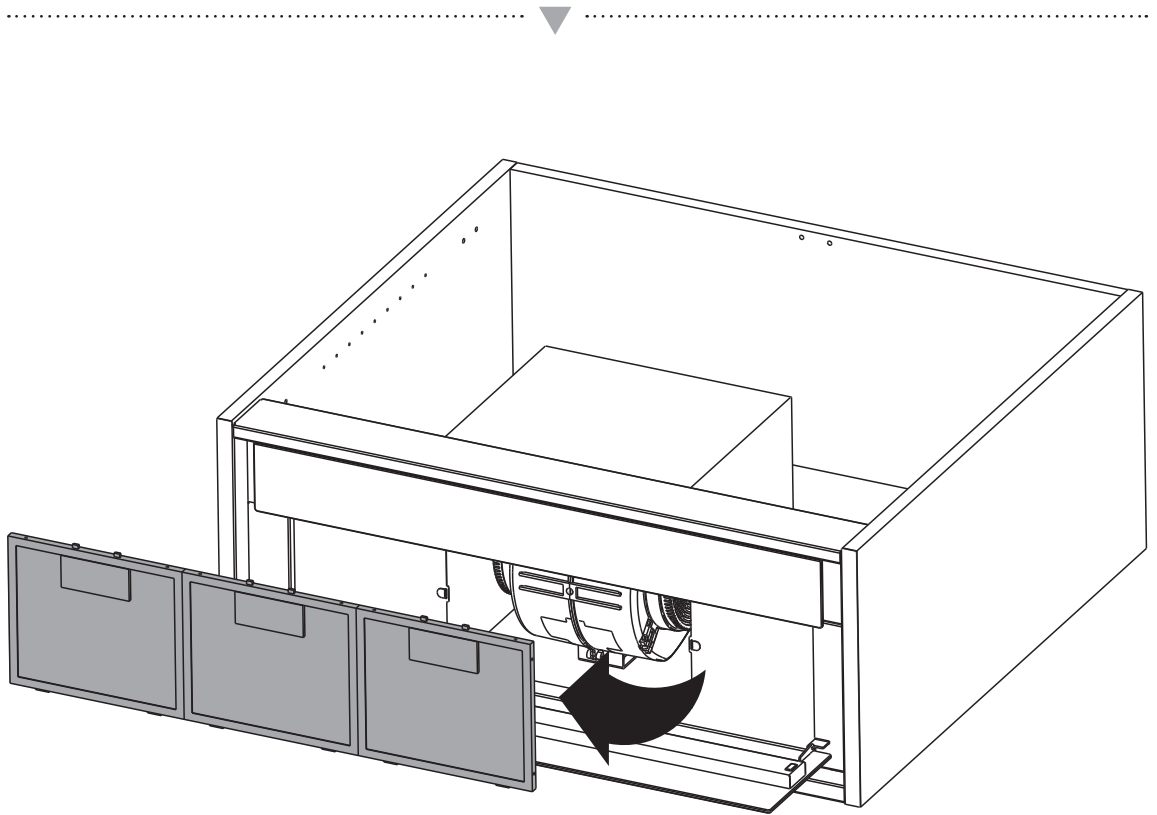
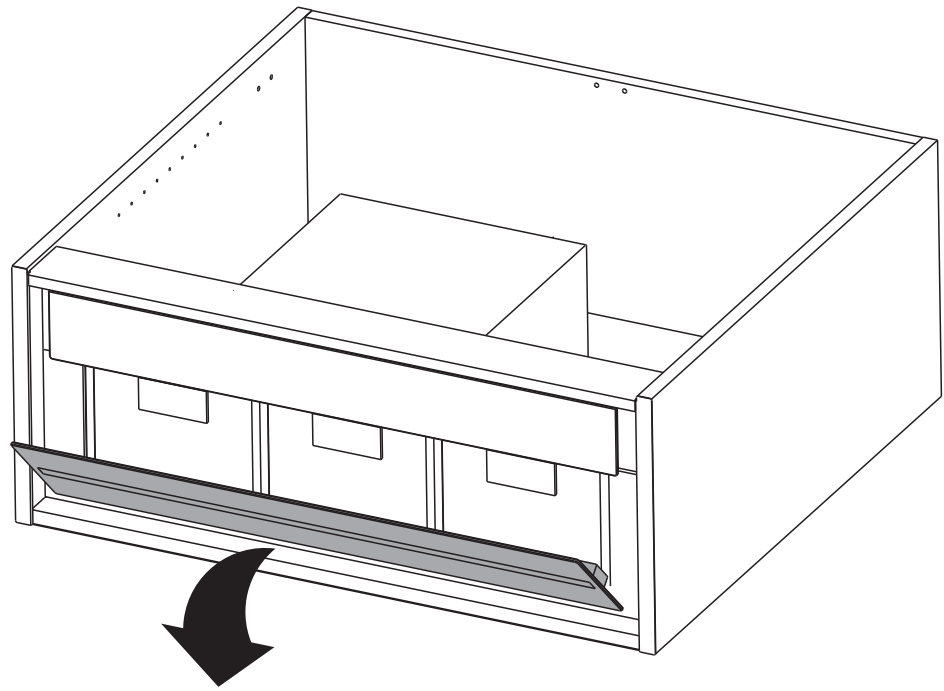



16



[04]x4
(3.5 x13mm)

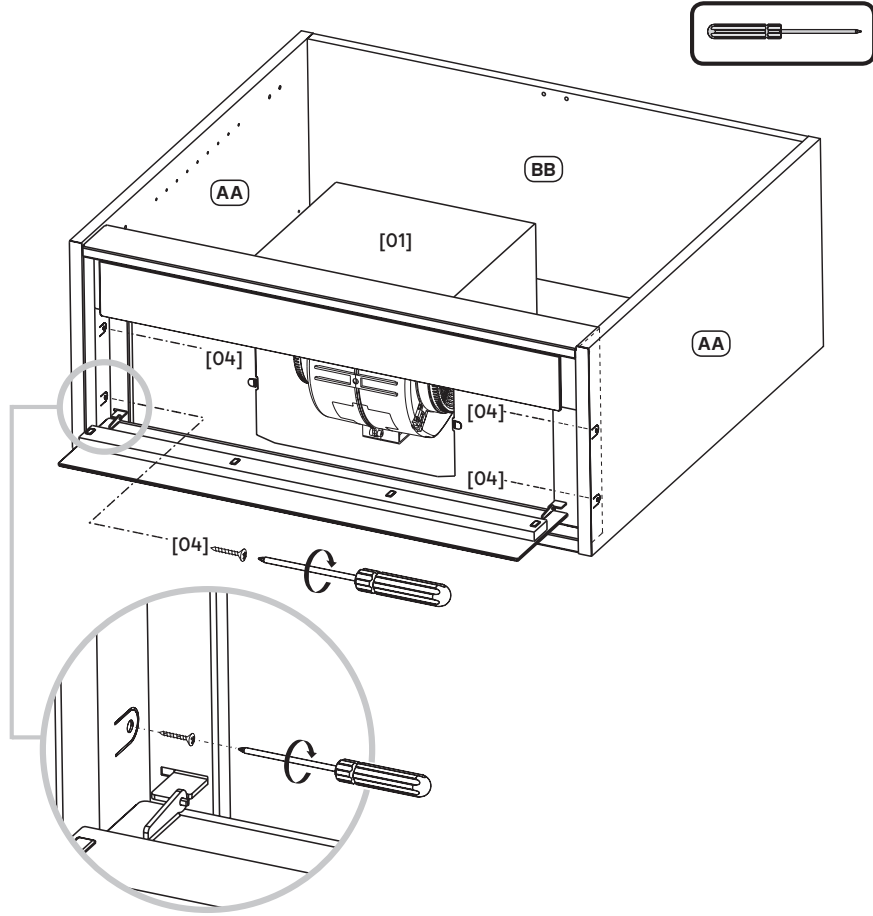

17



[04]x4
(3.5x13mm)

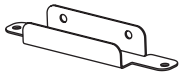

[03]x1



MYY x1

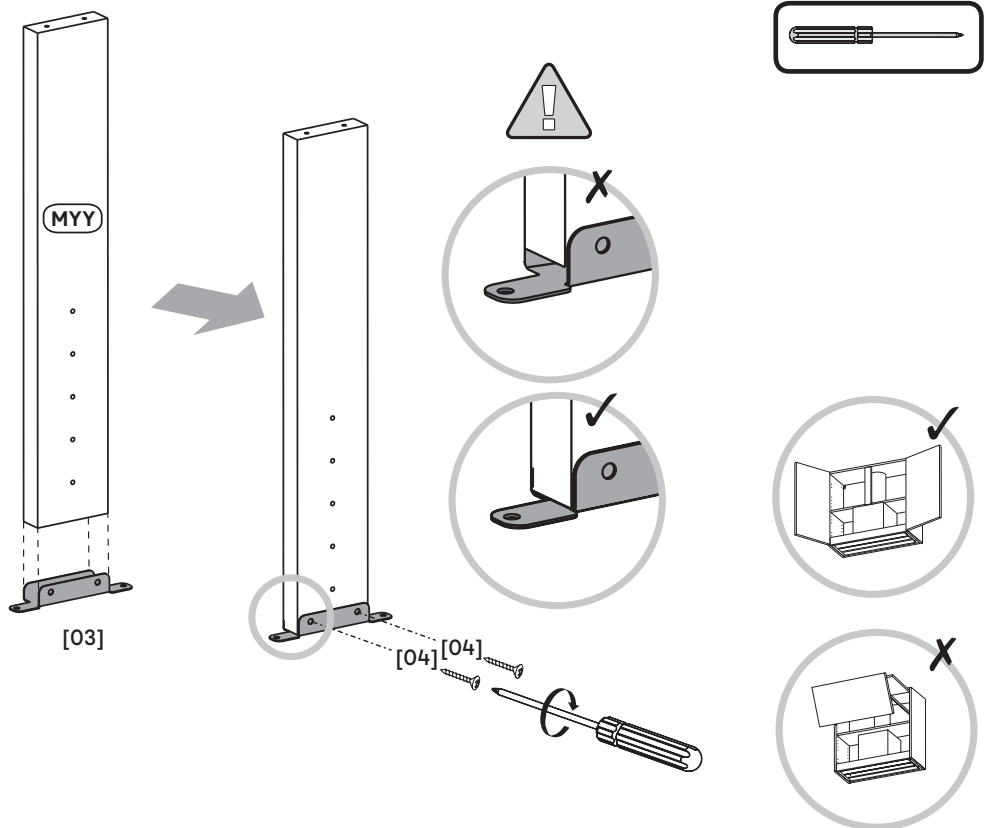



18

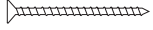

ⓐ 50mm X2



[05]x2
(3.5 x9.5mm)

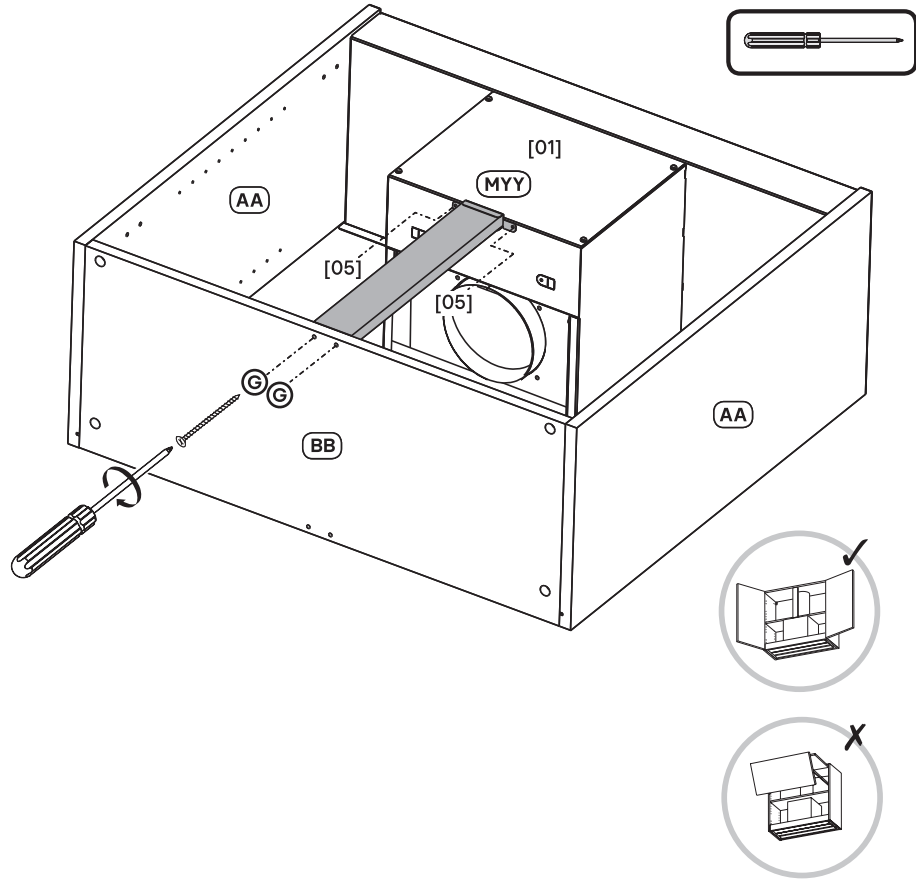

19



ⓐ 50mm X2



[04]x4
(3.5 x13mm)



MZZ x1

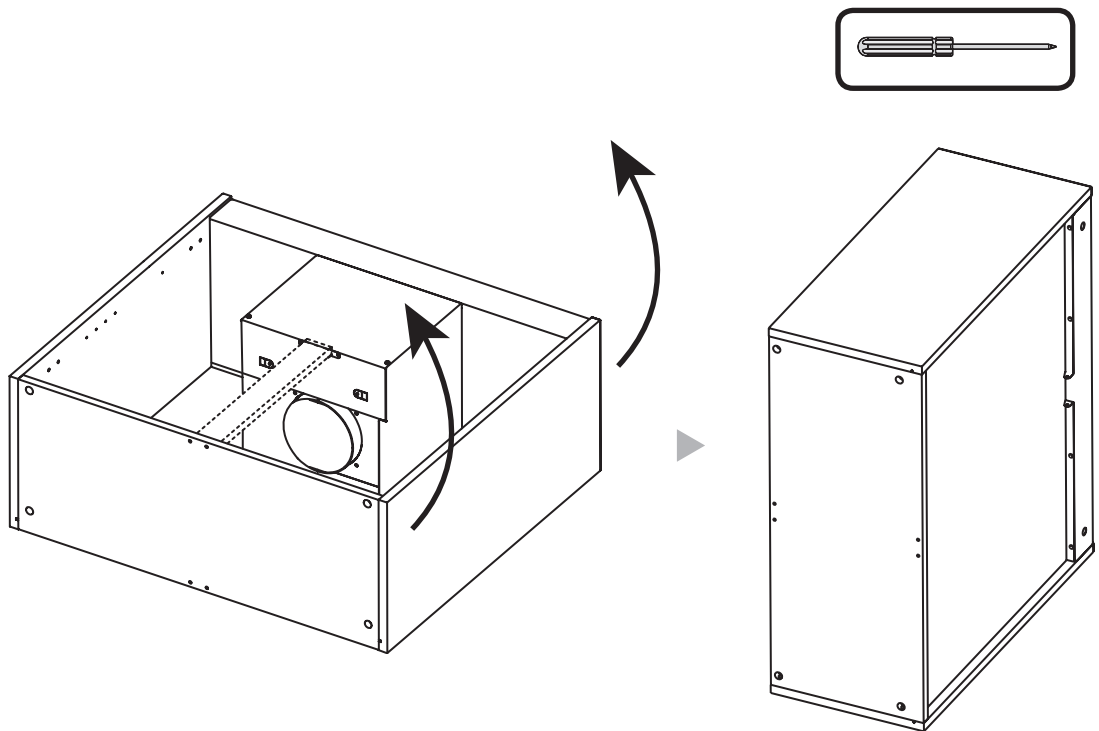

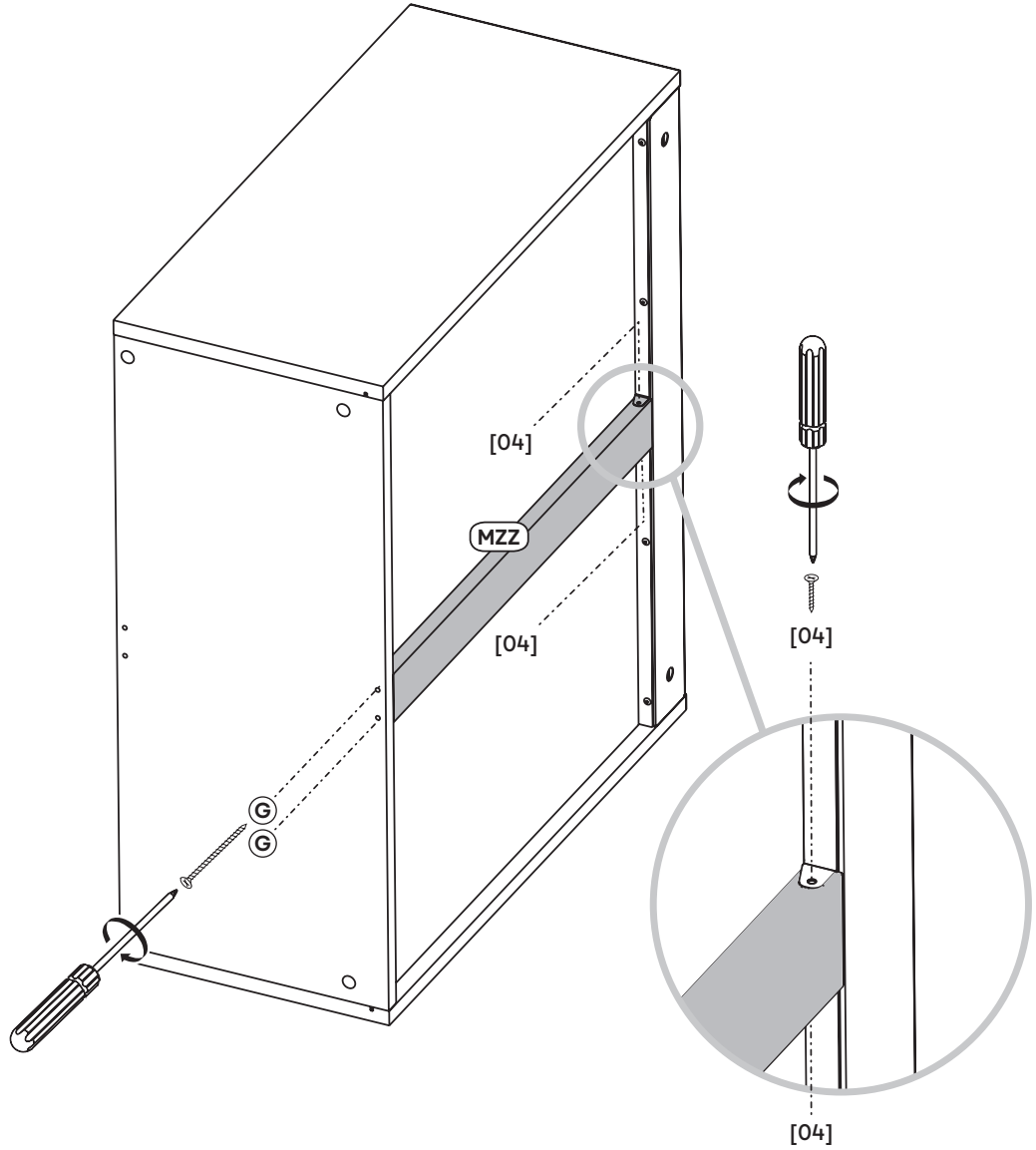

20

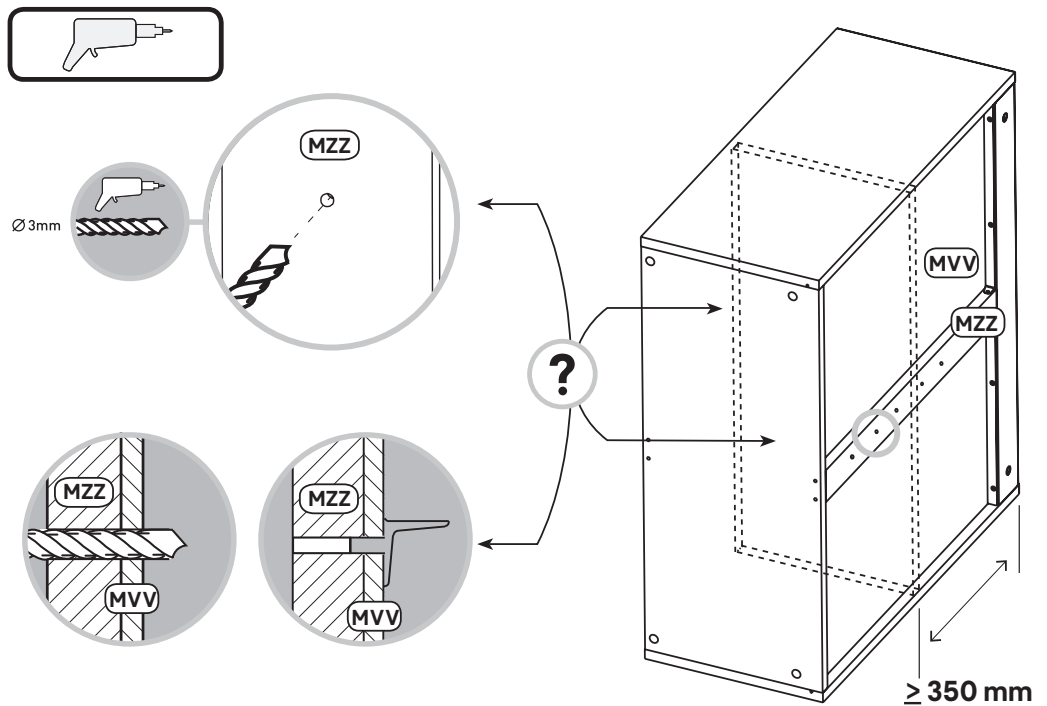



21

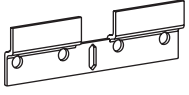

(P) x1

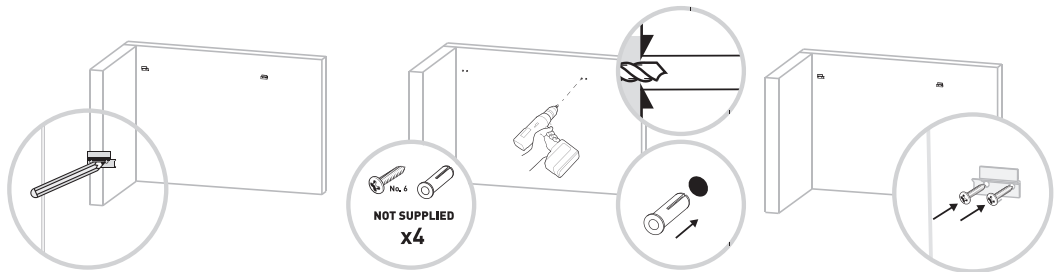
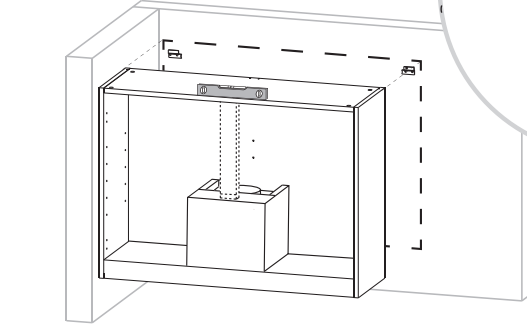
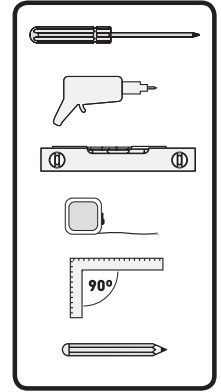
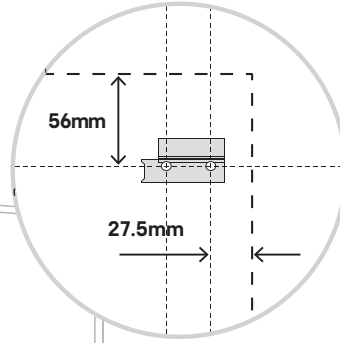
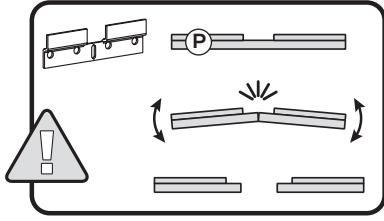

22

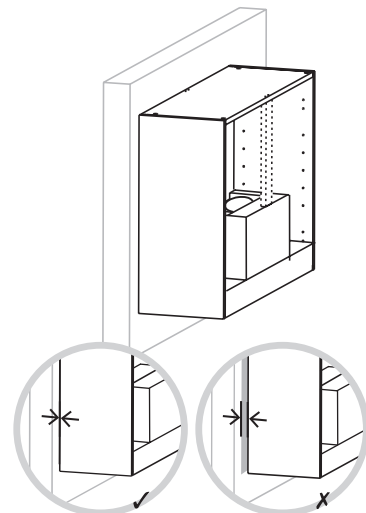
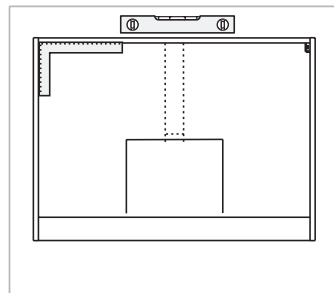
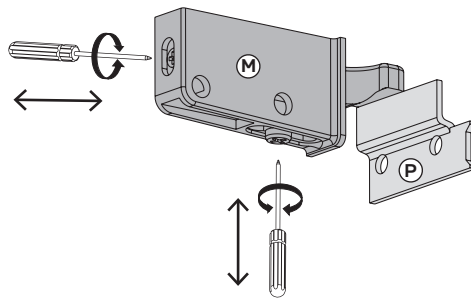
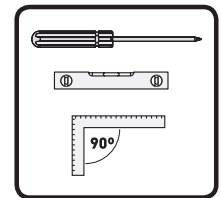
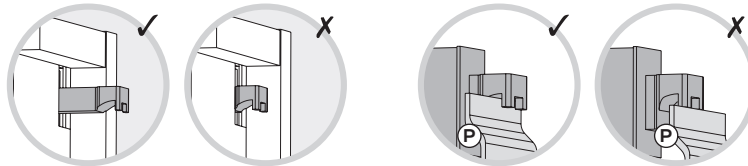



23



(F) 30mm x2

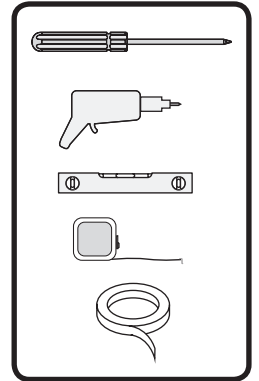
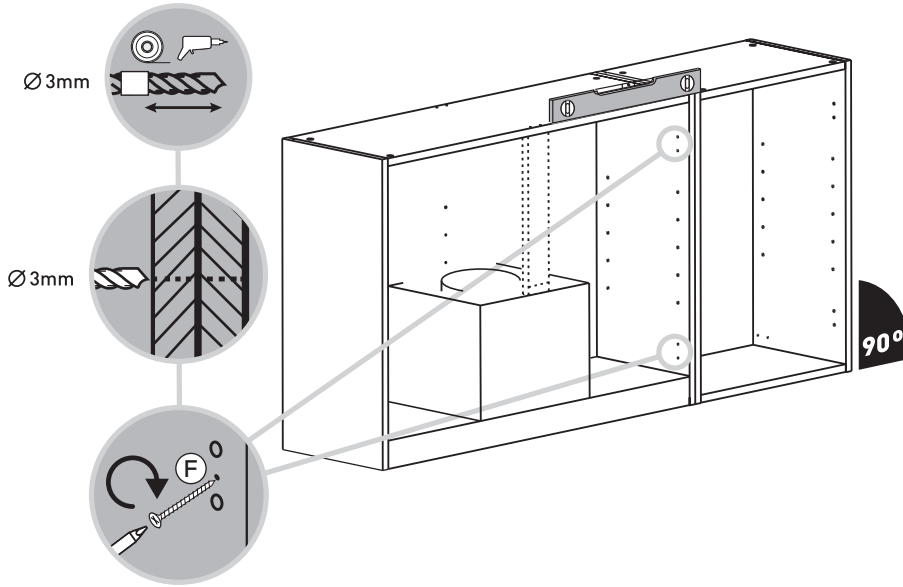

24



(J) x4

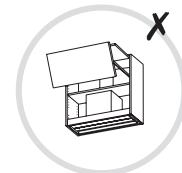
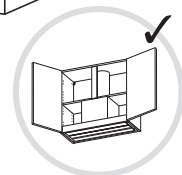
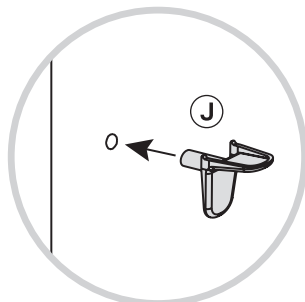
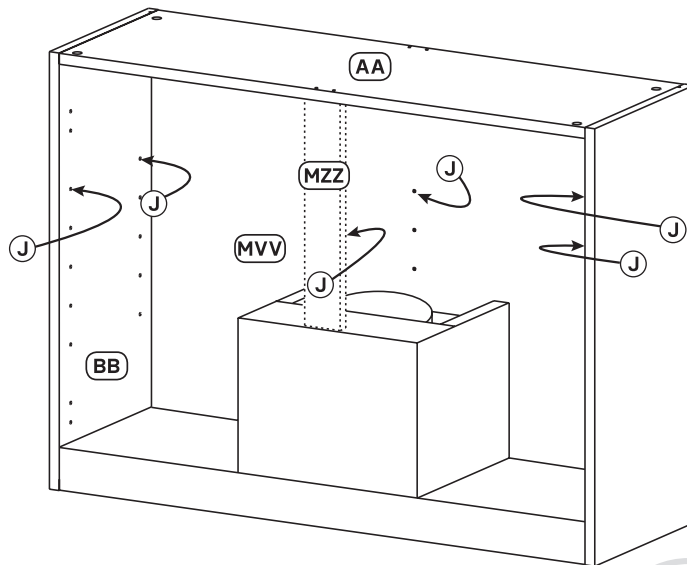



25



MXX x1

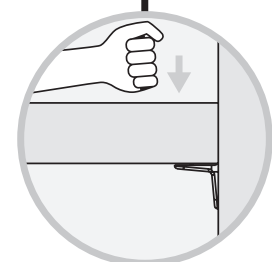
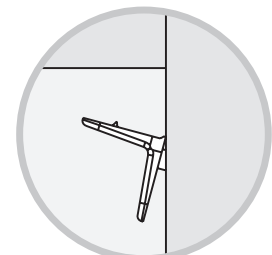
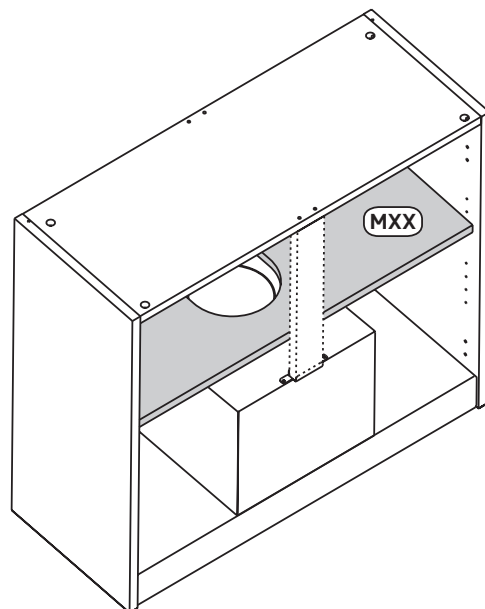
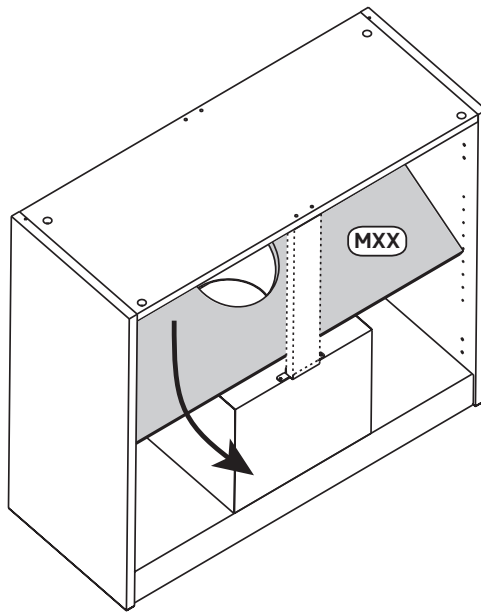
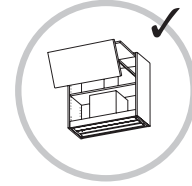
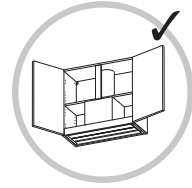
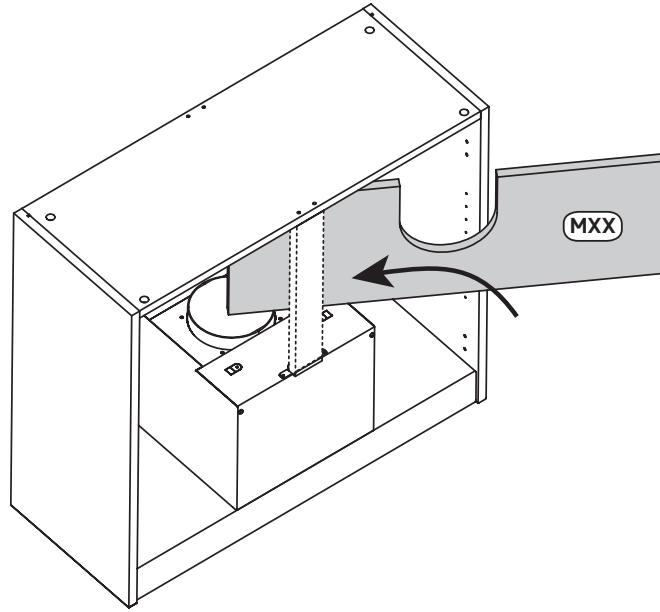



25

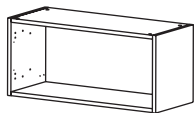

EN Bridging Wall Cabinet
80cm x 36cm

FR Armoire murale
suspendue
80 cm x 36 cm

PL Łącznikowa szafka
ścienna 80 cm x 36 cm

RO Dulap de perete de
legătură 80 cm x 36 cm

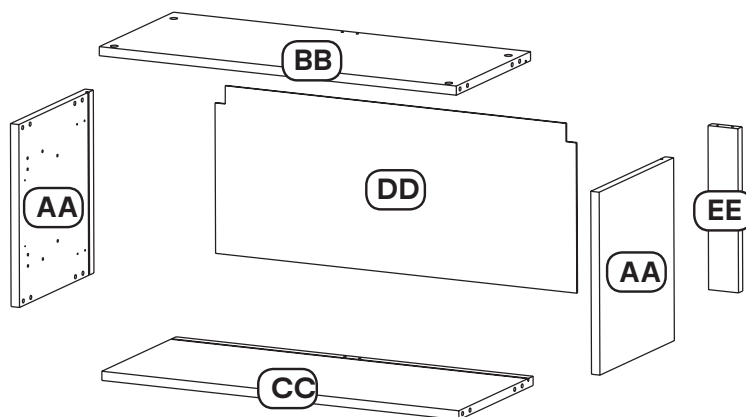
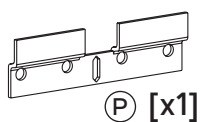
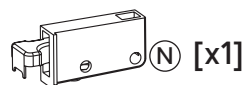
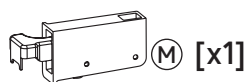
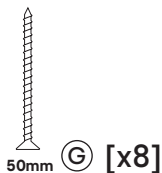
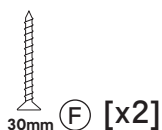
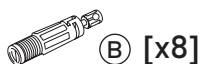

2 x AA	✓
1 x BB	→ 1 x MRR
1 x CC	→
1 x DD	→ 1 x MSS
1 x EE	→ 1 x MTT

EN Identify the parts in your cabinet that require modification to allow installation of the appliance.
Do not dispose of the surplus parts until installation is complete!

FR Identifier les pièces de votre armoire à modifier pour permettre l'installation de l'électroménager.
Ne pas jeter les pièces en trop avant la fin de l'installation !

PL Należy zidentyfikować części w szafce, które wymagają modyfikacji w celu umożliwienia instalacji urządzenia.
Nie należy usuwać części nadmiarowych przed zakończeniem instalacji!

RO Identificați elementele dulapului care necesită modificare pentru a permite instalarea aparatului.
Nu aruncați elementele în plus înainte de finalizarea instalării!



27

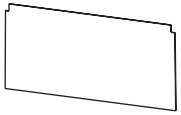
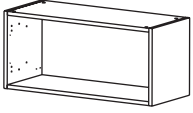

DD x1

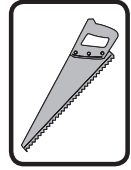
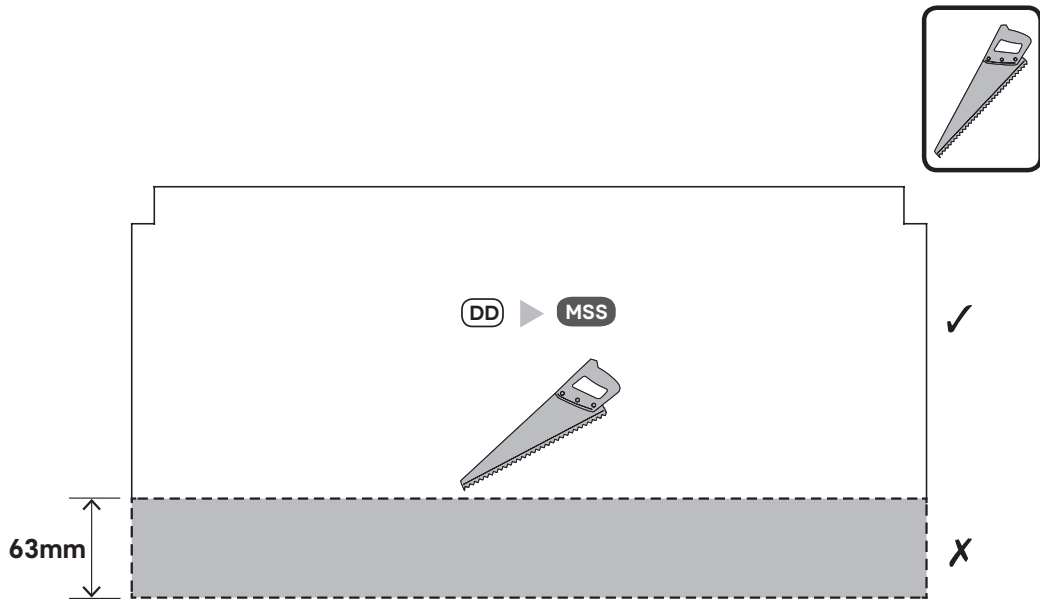

28

EE x1

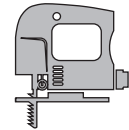
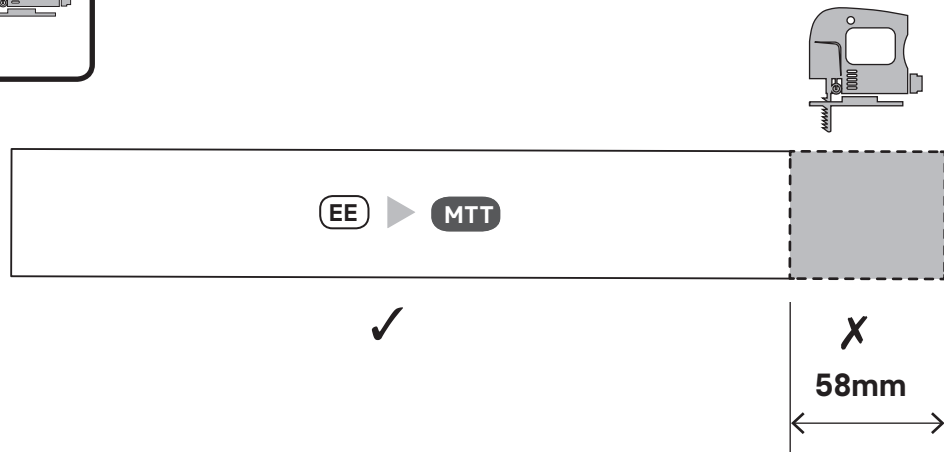
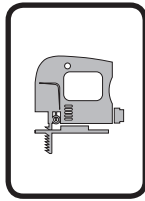

29

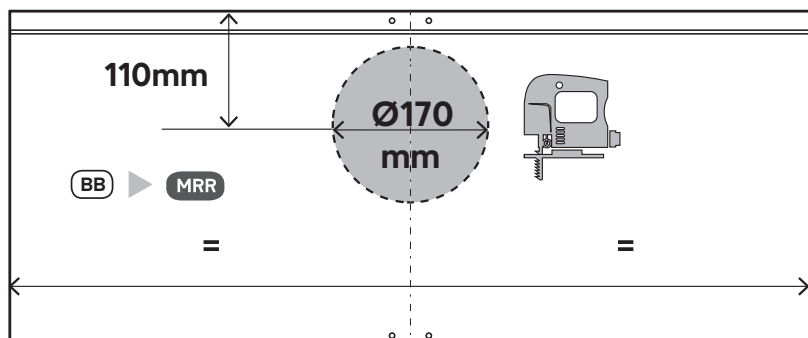
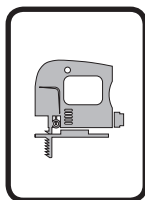



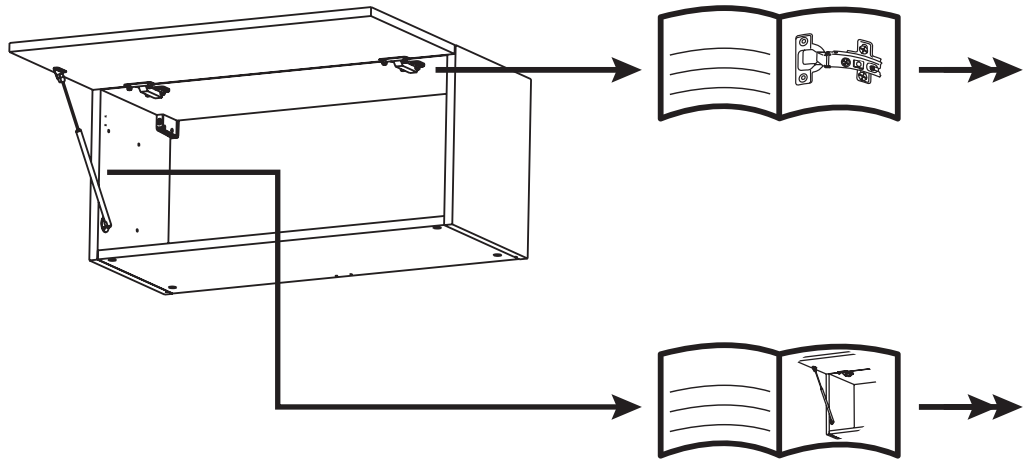

30

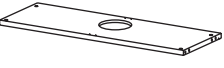

31

- A**  x8
- B**  x8
- C**  x8
-  **MRR** x1

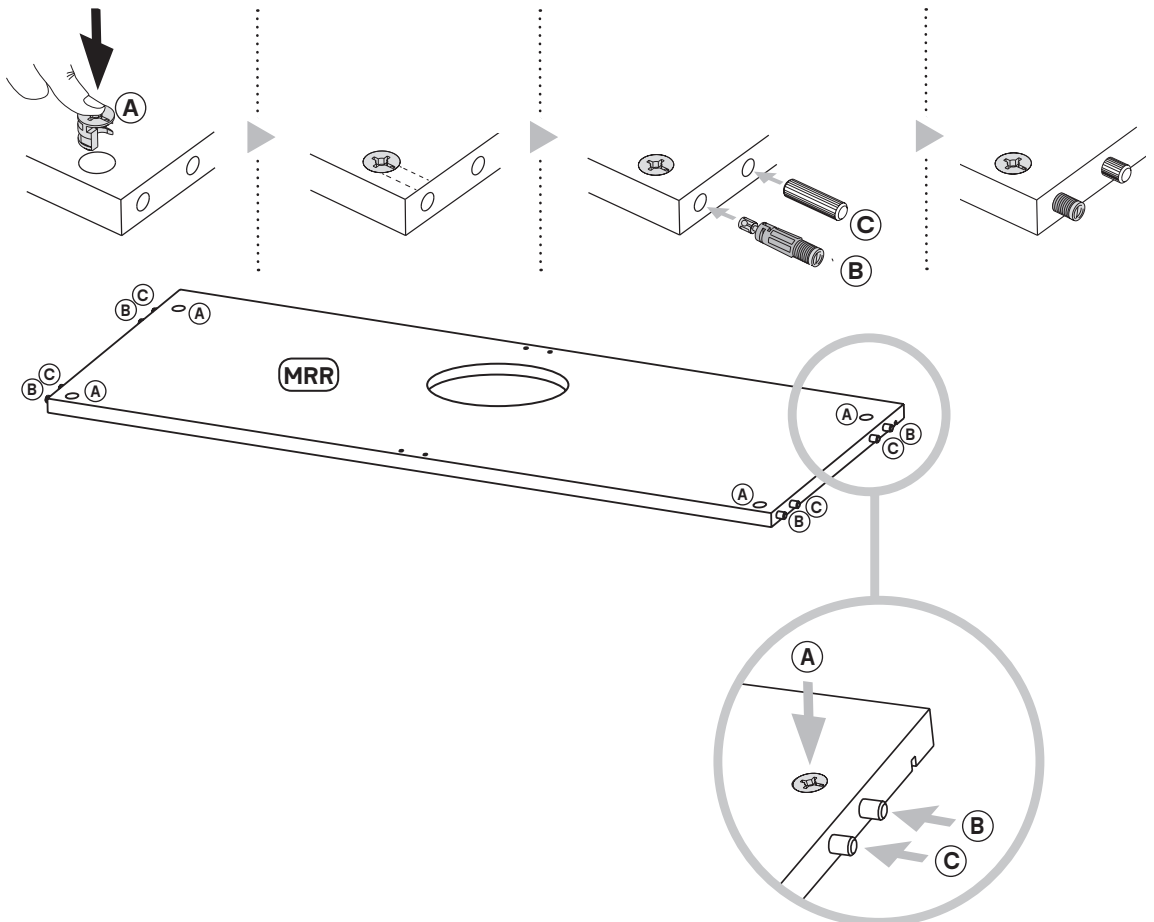



32

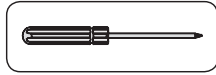

AL 16mm x4

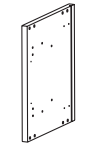
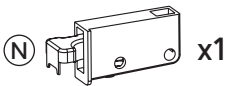
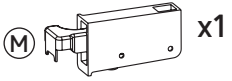

AA x2

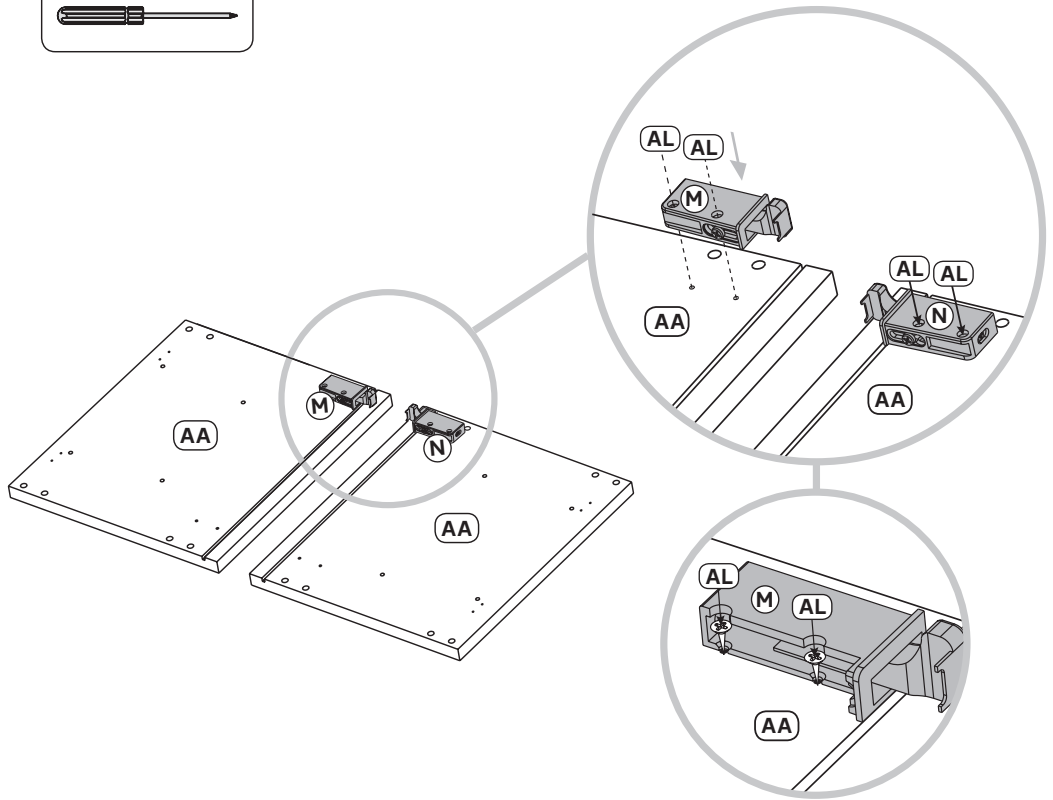

33

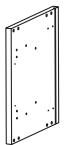
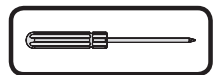

AA x2

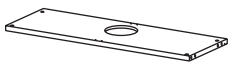

MRR x1

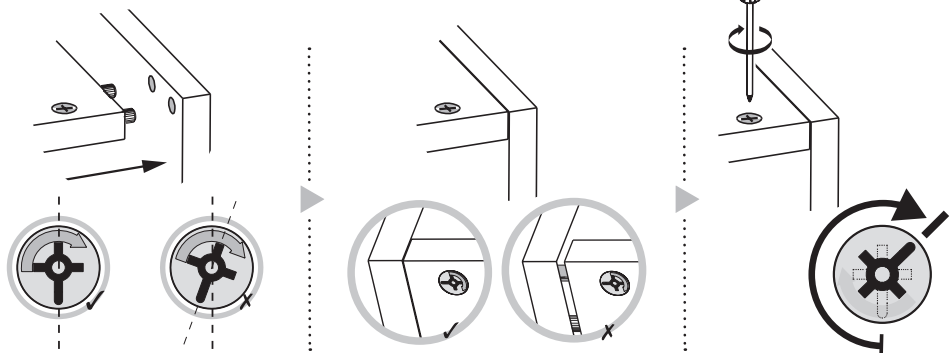
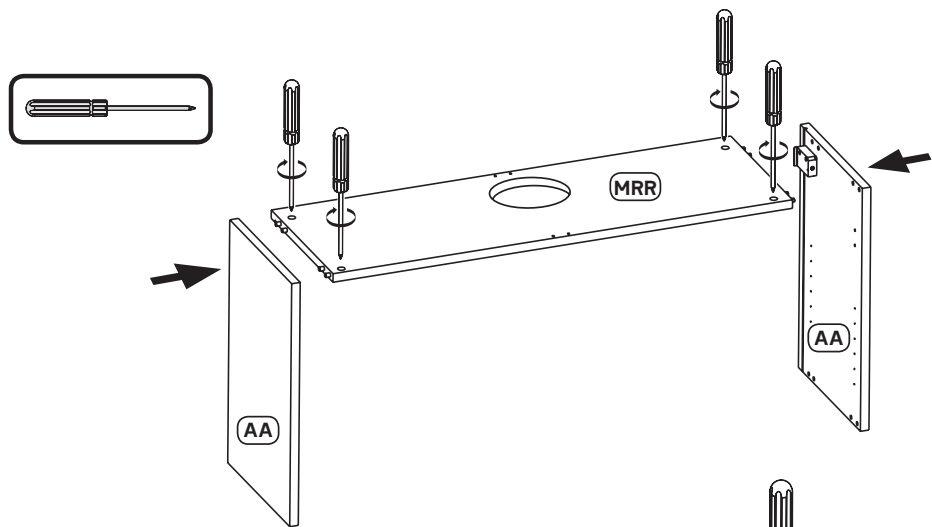



34

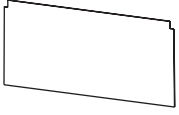

MSS x1

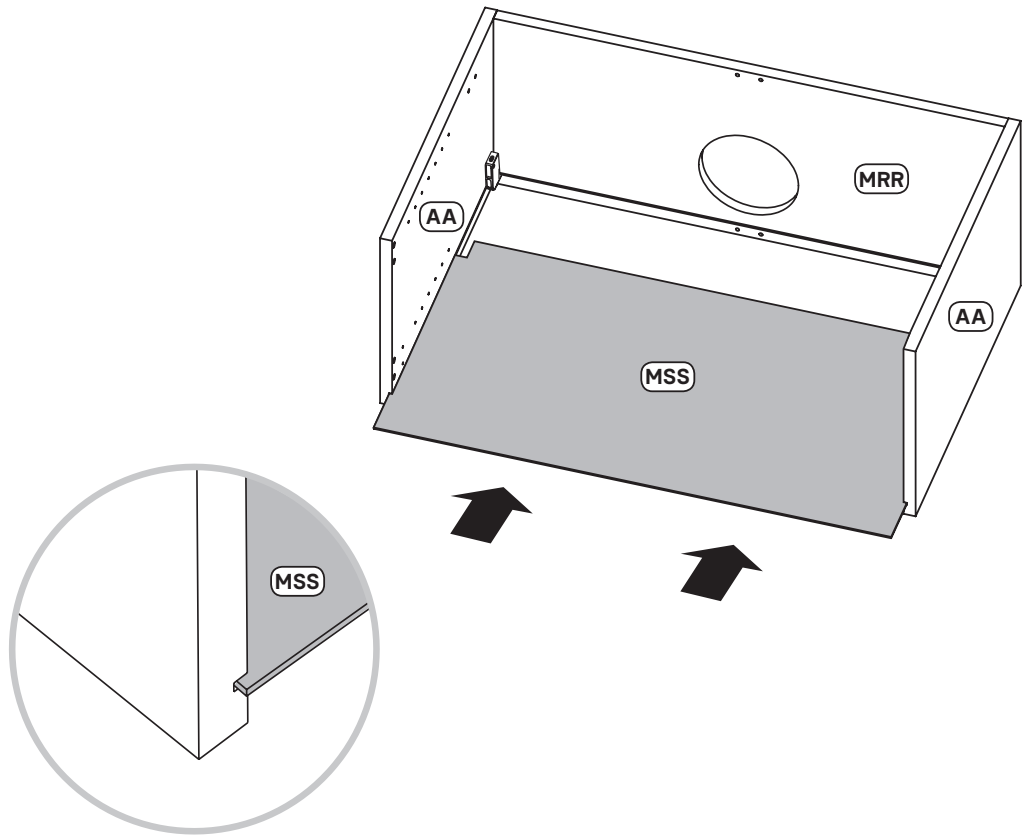

35

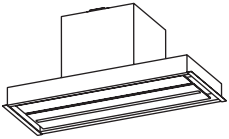

[01]x1

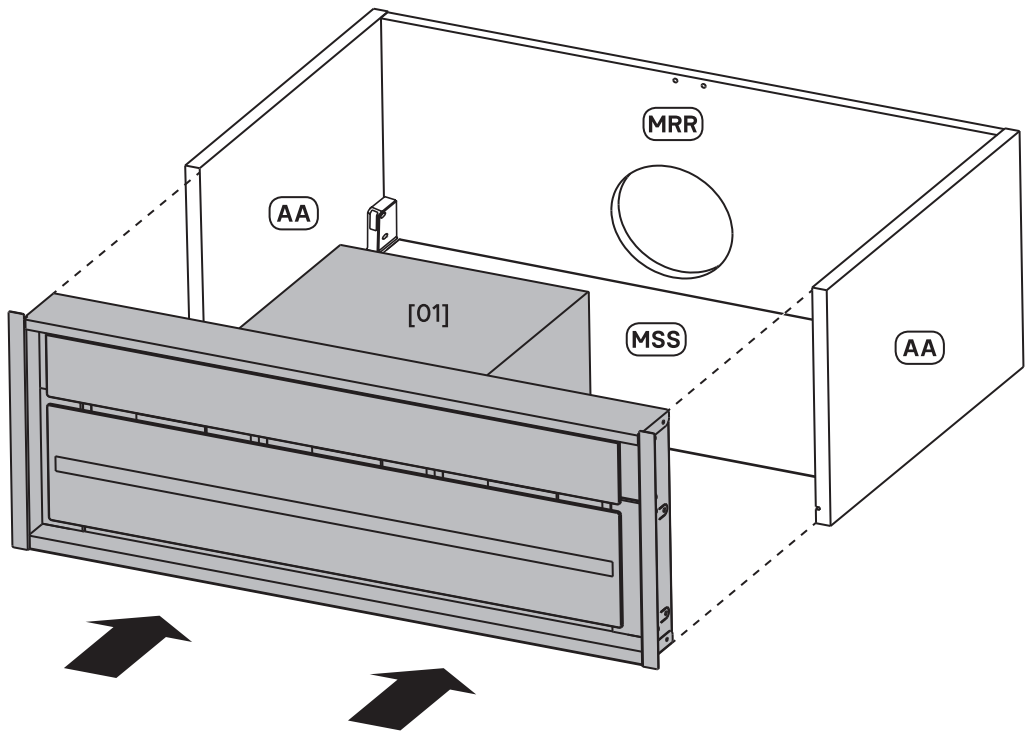

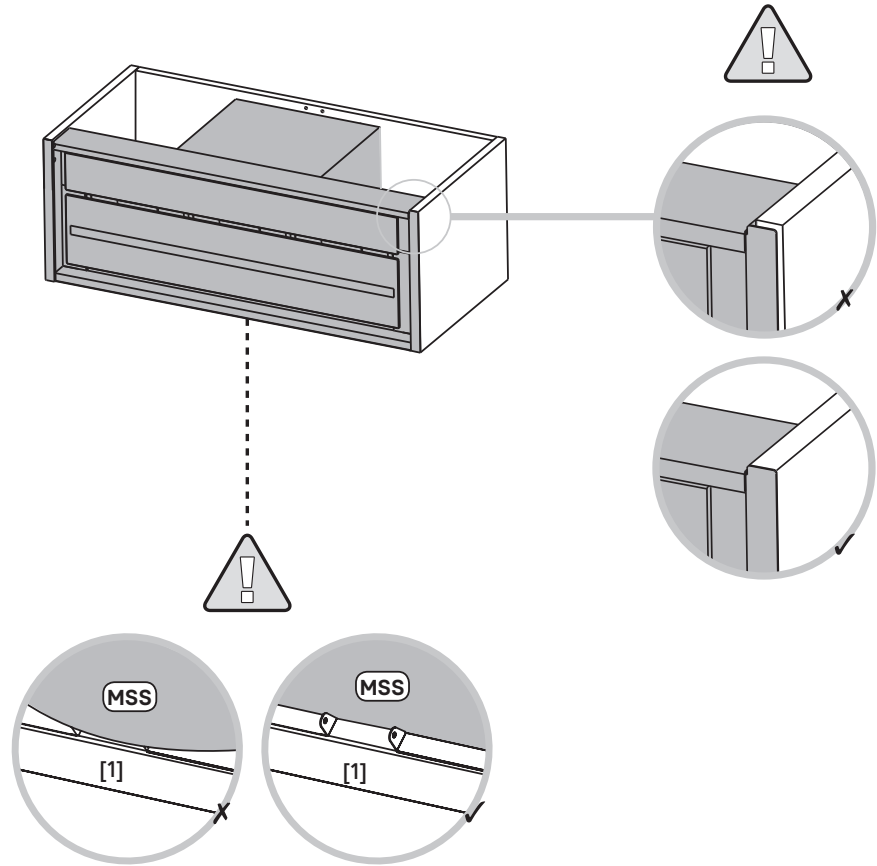

36

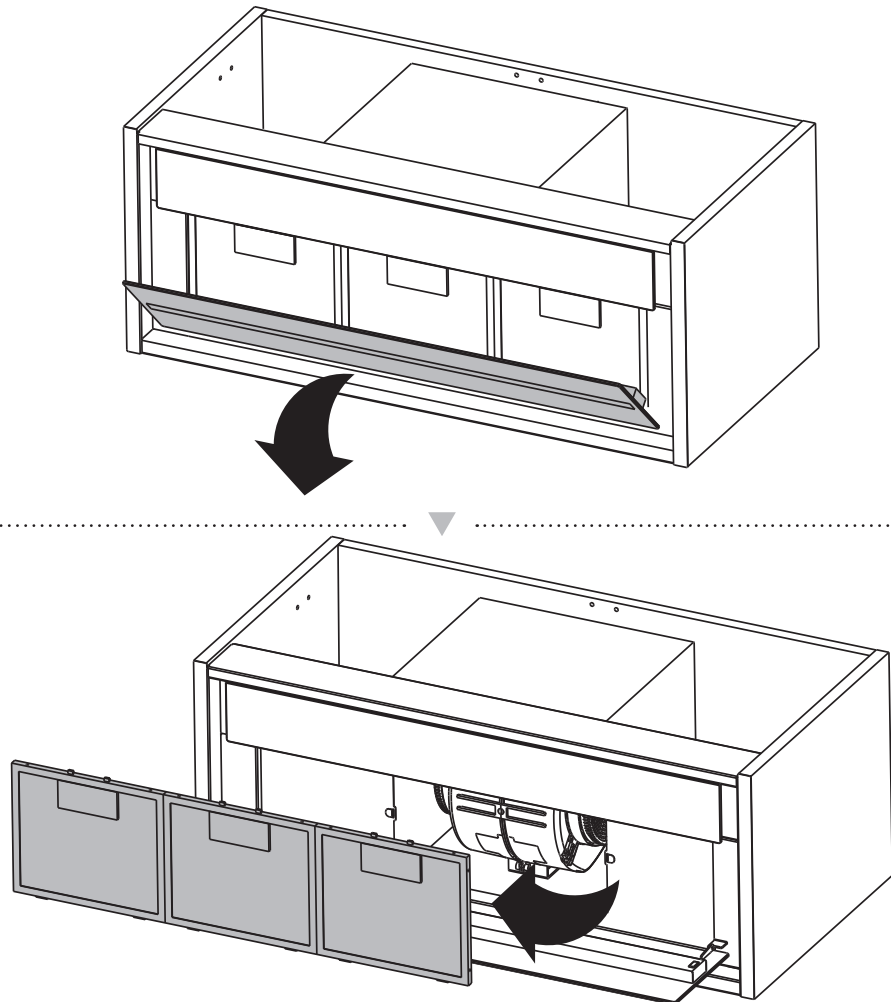



37



[04]x4
(3.5 x13mm)

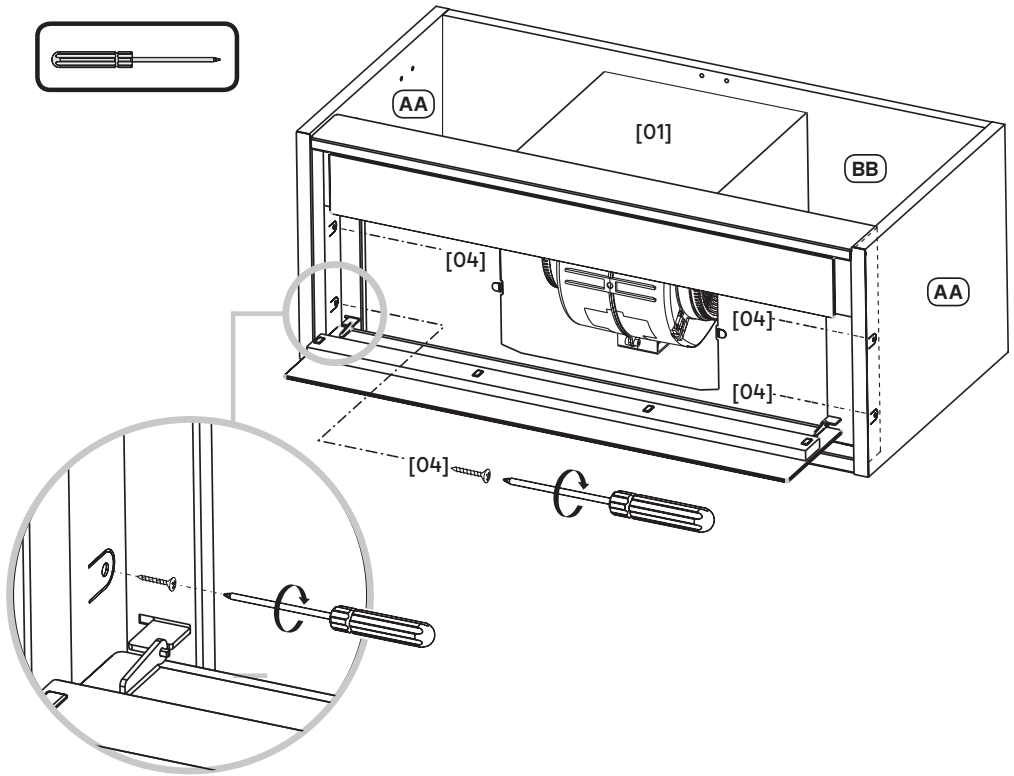
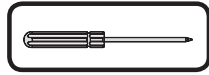

38



ⓐ 50mm x2



[04]x4
(3.5 x13mm)



MTT x1

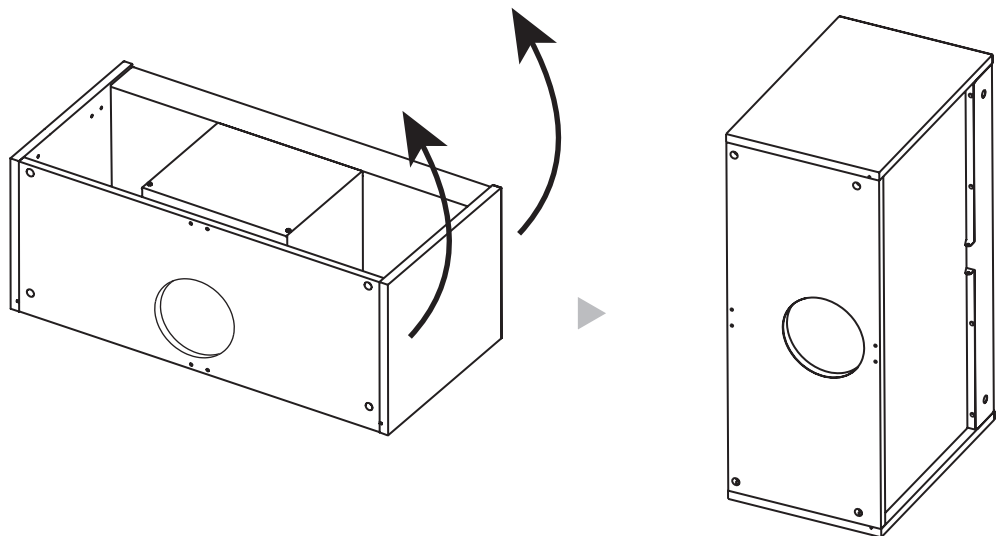
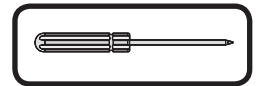



40

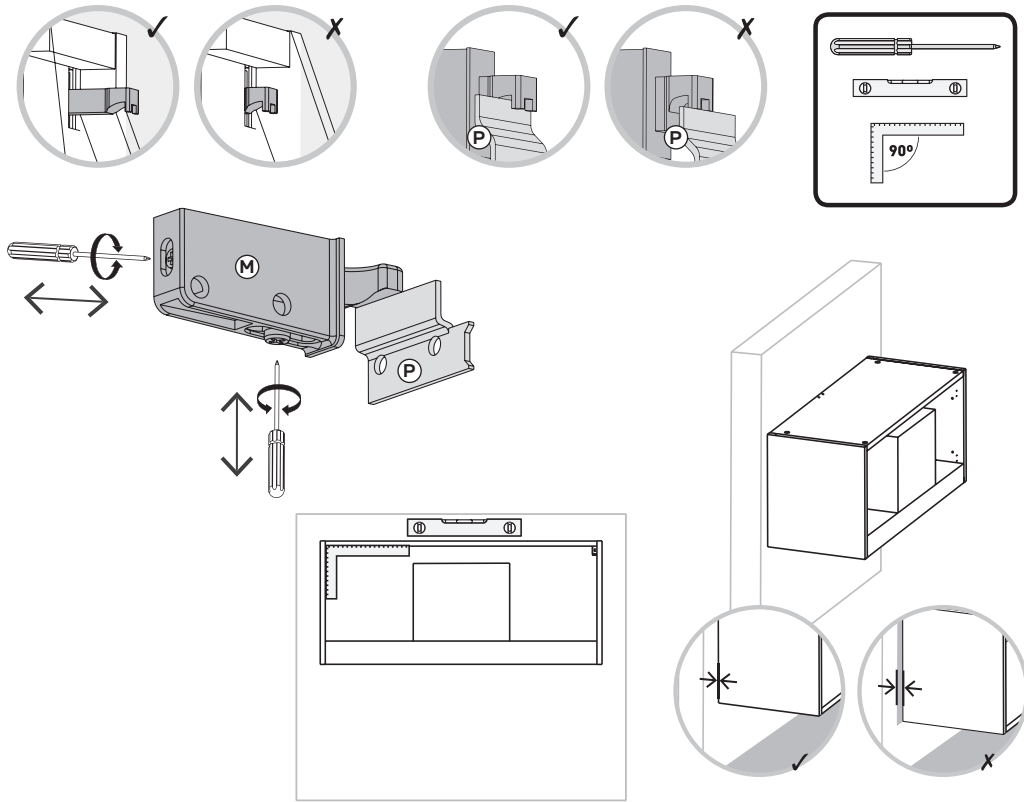

41

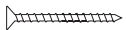

(F) 30mm X2

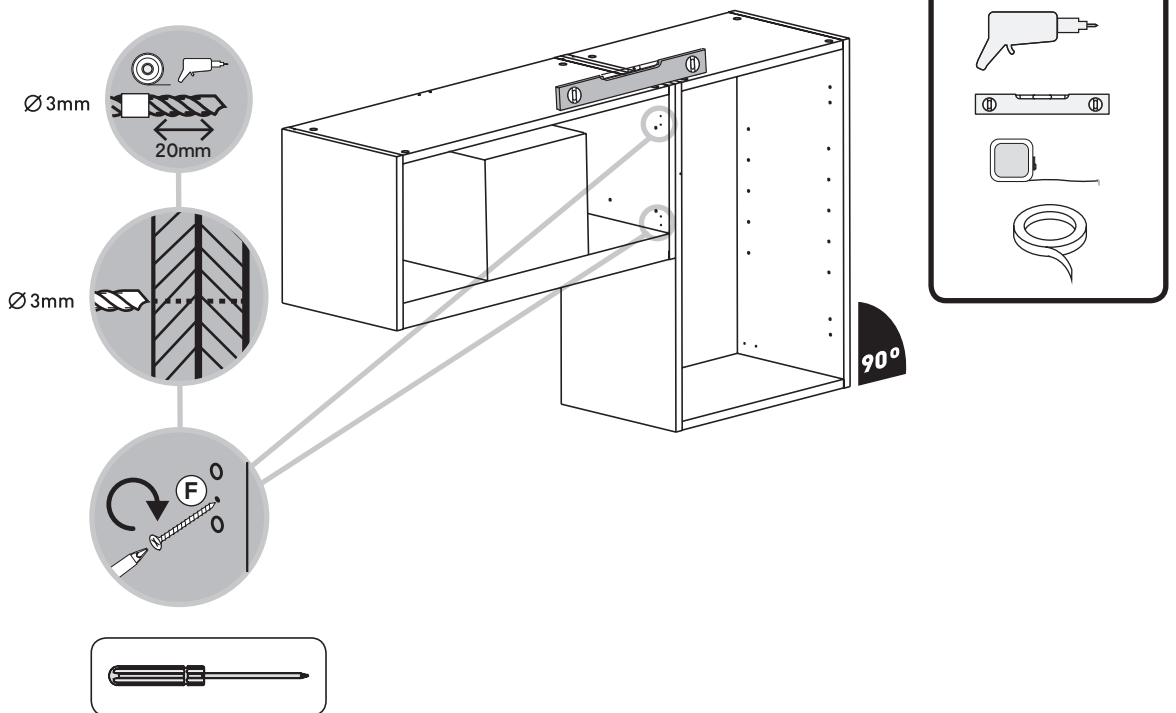



EN Electrical Installation

All installation must be carried out by a competent person or qualified electrician. Before connecting the mains supply ensure that the mains voltage corresponds to the voltage on the rating plate.

Direct Connection

The appliance must be connected directly to the mains using an omnipolar circuit breaker with a minimum opening of 3mm between the contacts.

The installer must ensure that the correct electrical connection has been made and that it complies with the wiring diagram.

The cable must not be bent or compressed.

Regularly check the power plug and power cord for damage. If the supply cord is damaged, it must be replaced by a special cord or assembly available from the manufacturer or its service agent.

WARNING: This is a Class I appliance and **MUST** be earthed.

This appliance is supplied with a 3 core mains cable coloured as follows:

Brown = L or Live

Blue = N or Neutral

Green and Yellow = E or Earth ⊕

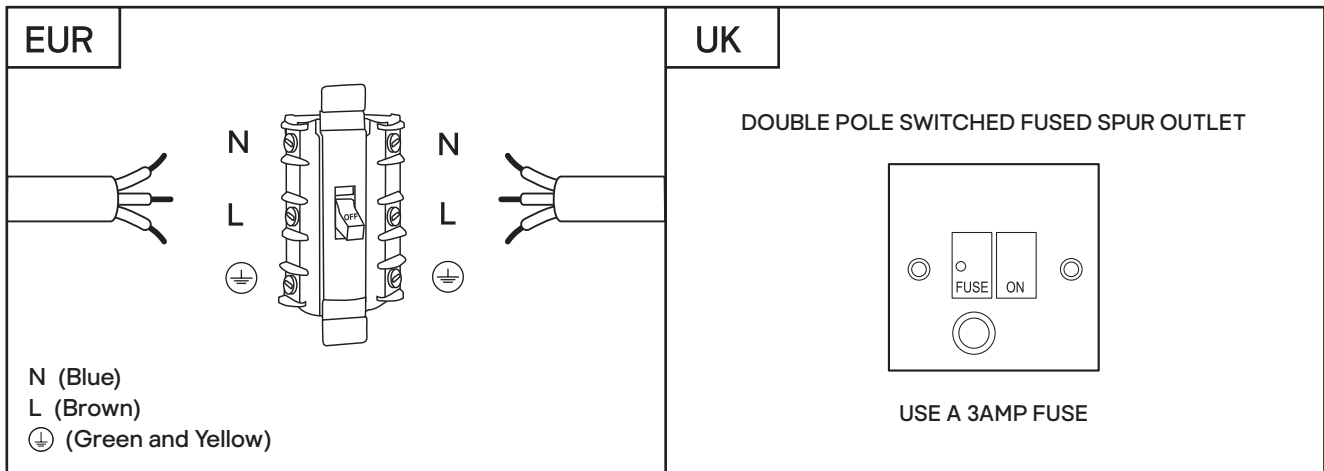

To avoid the risks that are always present when you use an electrical appliance it is important that this appliance is installed correctly and that you read the safety instructions carefully to avoid misuse and hazards. Please keep this instruction booklet for future reference and pass it on to any future owners. After unpacking the appliance please check that it is not damaged. If in doubt, do not use the appliance but contact Customer Services - see the end of the Care & Maintenance section for details.

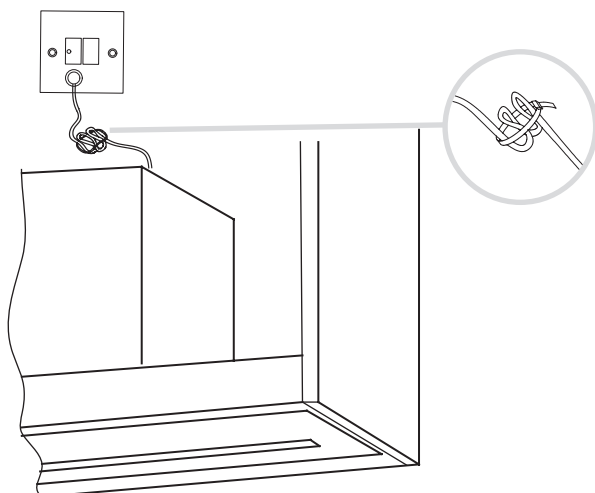

Once the electrical connection point and routing of the mains cable is established ensure that any excess cable is secured in such a way to prevent it falling into the motor housing and damaging the appliance.



FR Installation électrique

Toute l'installation doit être effectuée par une personne compétente ou un électricien qualifié. Avant de raccorder le câble d'alimentation, s'assurer que la tension de secteur corresponde à la tension indiquée sur la plaque signalétique.

Raccordement direct

L'électroménager doit être raccordé directement au secteur à l'aide d'un disjoncteur omnipolaire avec une ouverture minimale de 3 mm entre les contacts.

L'installateur doit s'assurer que le bon raccordement électrique a été effectué et qu'il respecte le schéma de câblage.

Le câble ne doit pas être plié ou comprimé.

Vérifier régulièrement la présence de dommages sur la fiche secteur et le cordon d'alimentation. Si le cordon d'alimentation est endommagé, il doit être remplacé par un cordon spécial ou un ensemble prévu à cet effet, disponible auprès du fabricant ou de son prestataire de service.

AVERTISSEMENT : il s'agit d'un appareil de Classe I. Il DOIT être raccordé à la terre.

Cet appareil est livré avec un câble secteur à 3 conducteurs présentant les couleurs suivantes :

Marron = L ou Phase

Bleu = N ou Neutre

Vert et jaune = E ou Terre ⊕

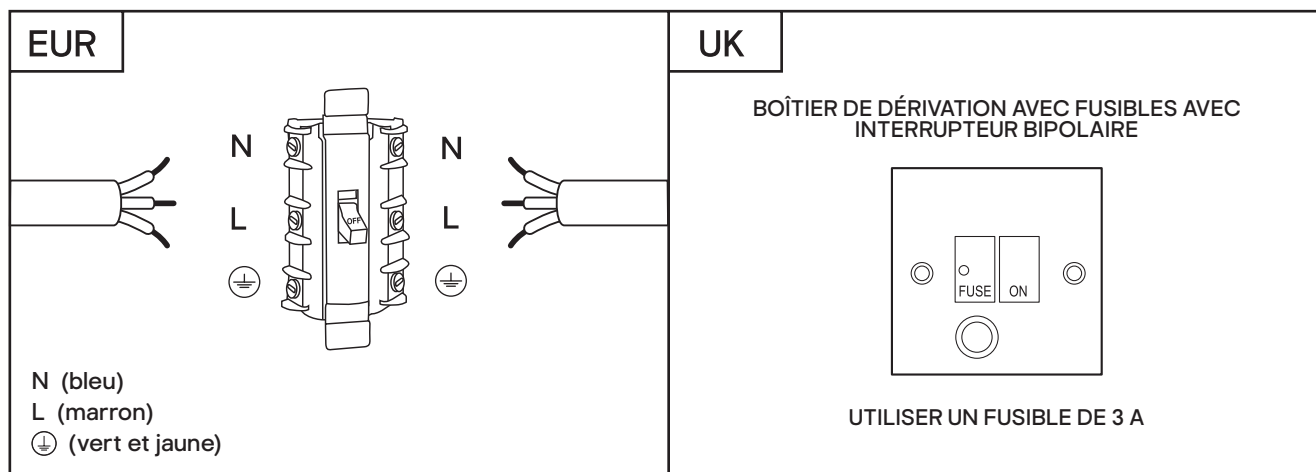

Afin d'éviter les risques, toujours présents lors de l'utilisation d'un appareil électrique, il est important que cet appareil soit correctement installé et de lire les instructions de sécurité soigneusement en vue d'empêcher tout danger ou toute mauvaise utilisation. Veiller à conserver ce manuel d'instructions pour référence ultérieure et à le transmettre à tout futur propriétaire. Après avoir déballé l'appareil, vérifier qu'il n'est pas endommagé. En cas de doute, ne pas utiliser l'électroménager, contacter le service client (voir la fin de la section Entretien et maintenance pour plus de détails).

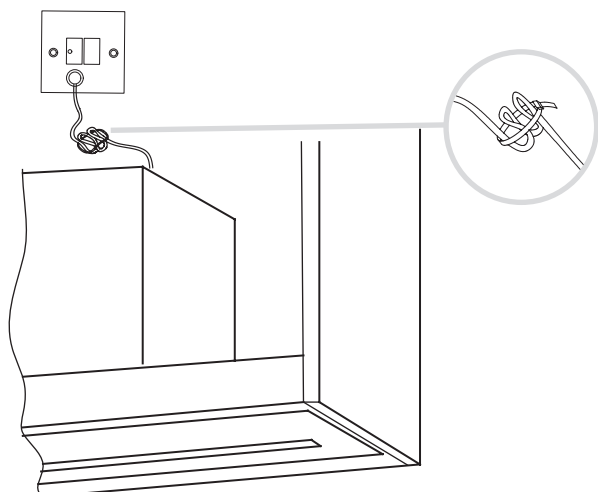

Une fois le raccordement électrique effectué et l'acheminement du câble secteur établi, s'assurer que le câble en excès est fixé de manière à l'empêcher de tomber dans le boîtier du moteur et d'endommager l'appareil.



PL Montaż elementów elektrycznych

Montaż musi zostać wykonany przez osobę kompetentną lub wykwalifikowanego elektryka. Przed podłączeniem zasilania upewnić się, czy napięcie zasilania odpowiada napięciu na tabliczce znamionowej.

Podłączenie bezpośrednie

Urządzenie należy podłączyć bezpośrednio do sieci zasilającej, korzystając z wyłącznika wielobiegowego o minimalnym odstępie między stykami wynoszącym 3 mm.

Monter powinien upewnić się, czy zostało wykonane odpowiednie połączenie elektryczne oraz czy jest ono zgodne ze schematem połączeń.

Przewód nie może być zagięty ani zgnieciony.

Należy regularnie sprawdzać wtyk i przewód zasilania pod kątem uszkodzeń. Jeśli przewód zasilania jest uszkodzony, należy go wymienić na odpowiadający przewód lub zespół dostępny u producenta lub u jego przedstawiciela serwisowego.

OSTRZEŻENIE: Jest to urządzenie klasy I i MUSI być uziemione.

Urządzenie jest dostarczane z 3-żyłowym przewodem zasilającym o następujących kolorach:

Brązowy = L (pod napięciem)

Niebieski = N (neutralny)

Zielono-żółty = E lub uziemienie ⊕

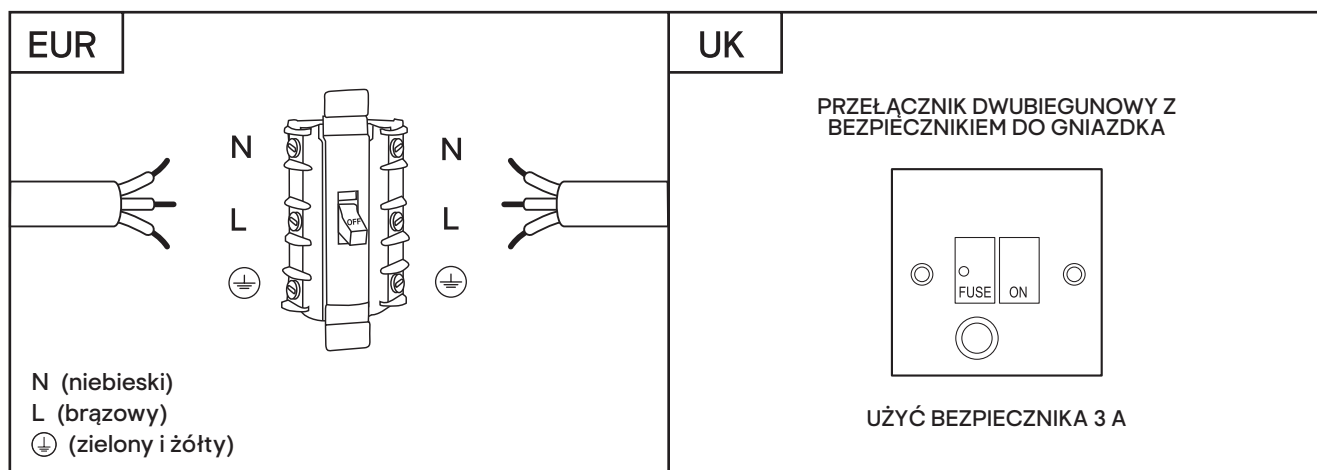

Aby ograniczyć do minimum ryzyko związane z użytkowaniem urządzenia elektrycznego, niezwykle ważne jest, aby produkt został prawidłowo zamontowany oraz aby użytkownik dokładnie zapoznał się z instrukcjami dotyczącymi bezpieczeństwa i unikał nieprawidłowej obsługi oraz związanych z tym zagrożeń. Należy zachować instrukcję obsługi w celu wykorzystania w przyszłości i przekazania jej kolejnym właścicielom. Po rozpakowaniu urządzenia upewnić się, że nie jest ono uszkodzone. W przypadku wątpliwości nie używać urządzenia i skontaktować się z działem obsługi klienta. Więcej szczegółowych informacji znajduje się na końcu części Konserwacja i utrzymanie.

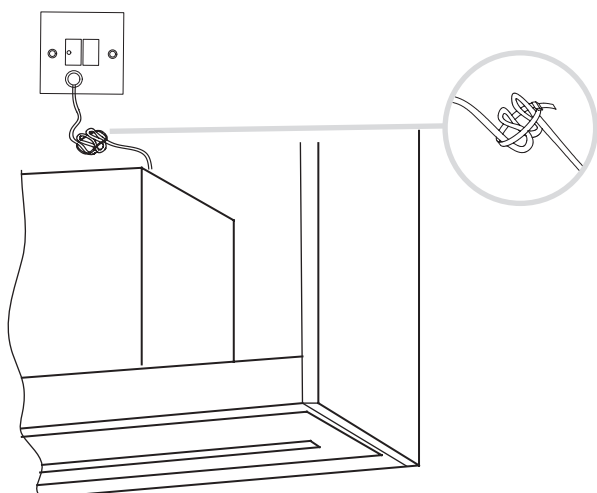

Po określeniu punktu połączenia elektrycznego i poprowadzeniu przewodu zasilania należy upewnić się, że nadmiar przewodu jest zabezpieczony w taki sposób, aby uniemożliwić mu upadek na obudowę silnika i uszkodzenie urządzenia.



RO Conectarea la alimentarea electrică

Instalarea trebuie să fie realizată în totalitate de o persoană competentă sau de un electrician calificat. Înainte de conectarea la rețeaua electrică, asigurați-vă că tensiunea rețelei corespunde cu tensiunea de pe plăcuța de identificare.

Conexiune directă

Aparatul trebuie conectat direct la rețea cu ajutorul unui disjunctor omnipolar cu o deschidere minimă între contacte de 3 mm.

Instalatorul trebuie să se asigure că a realizat corect legăturile electrice și că a respectat schema electrică.

Cablul nu trebuie să fie îndoit sau comprimat.

Verificați periodic ștecărul și cablul pentru a depista deteriorările. În cazul în care cablul de alimentare este deteriorat, trebuie înlocuit cu un cablu special sau cu o instalație puse la dispoziție de producător sau agentul de service.

AVERTISMENT: Acesta este un aparat Clasa I și **TREBUIE** împământat.

Acest aparat este echipat cu un cablu de alimentare cu 3 fire, colorate după cum urmează:

Maro = L sau fază

Albastru = N sau nul

Verde și galben = E sau împământare ⊕

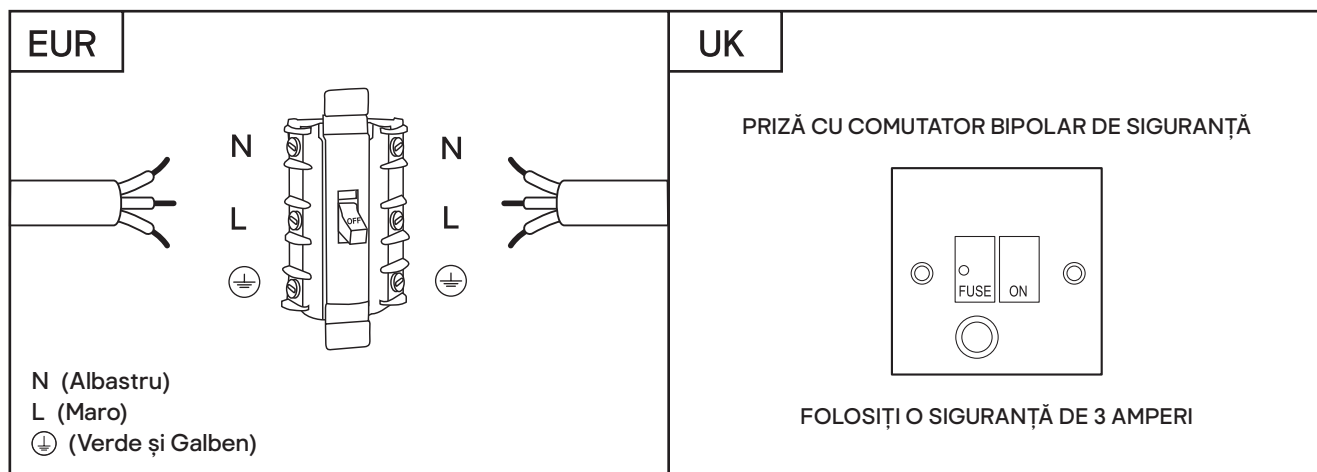

Pentru a evita riscurile aferente utilizării unui echipament electric, este important ca acest aparat să fie instalat corect și să citiți cu atenție instrucțiunile de siguranță, ca să evitați utilizarea greșită și pericolele. Păstrați această broșură cu instrucțiuni pentru consultare ulterioară și predați-o proprietarilor viitori. După despachetarea aparatului, verificați să nu fie deteriorat. Dacă aveți îndoieli, nu folosiți aparatul, ci contactați Serviciul de asistență clienți - consultați sfârșitul secțiunii Îngrijire și întreținere pentru detalii.

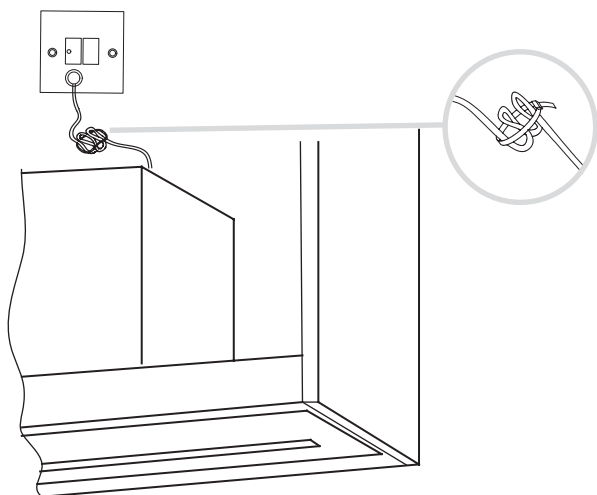

După stabilirea rutei și amplasării cablurilor electrice, toate cablurile suplimentare trebuie asigurate astfel încât să se împiedice căderea acestora în carcasa motorului, deteriorând în acest fel aparatul.



A
42

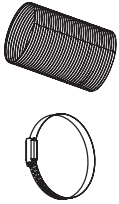

- EN Only for ducted option.
FR Uniquement pour l'option avec conduit.
PL Tylko dla opcji z kanałowej.
RO Numai pentru opțiunea de montare cu tubulatură.

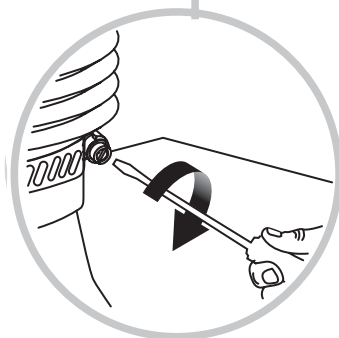
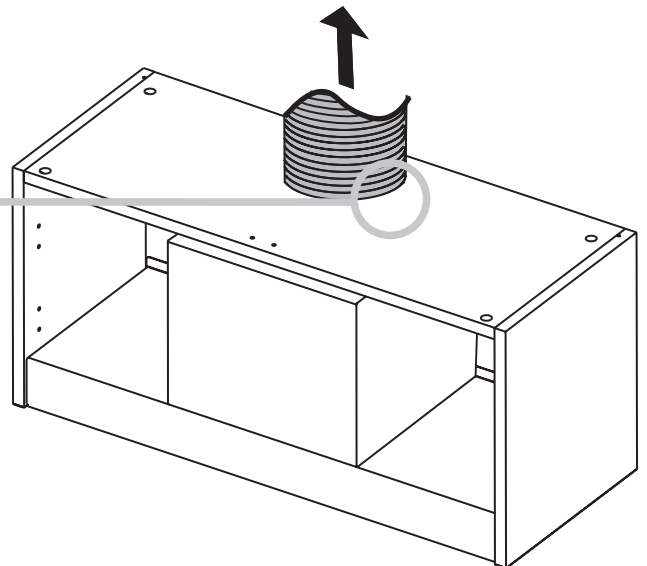
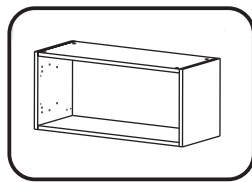
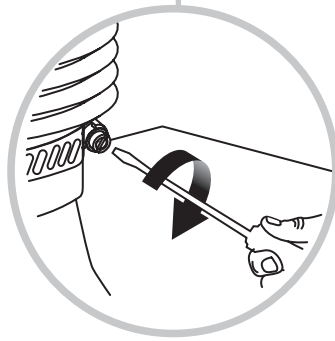
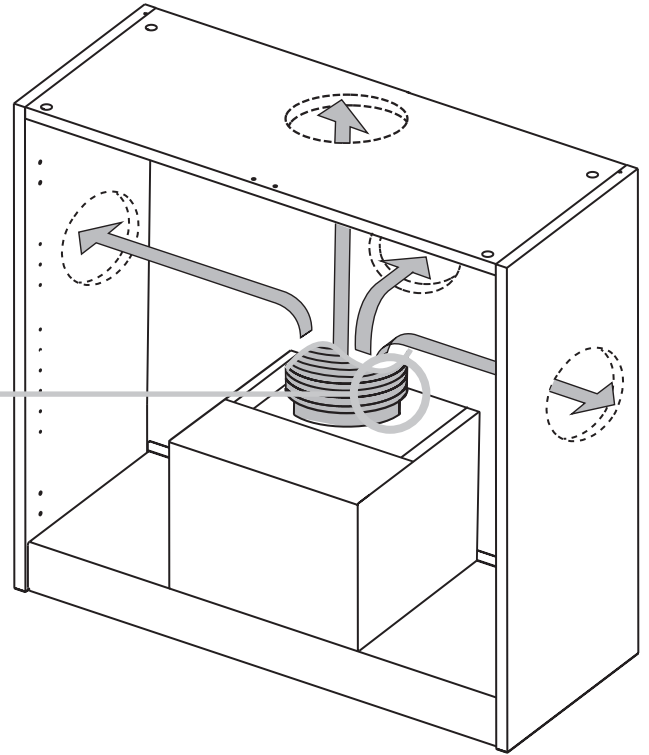
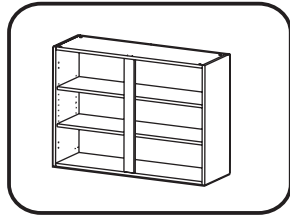



B

43

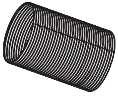

CARBFILT 50

- EN Only for recirculation option.
FR Uniquement pour l'option de recyclage.
PL Tylko dla opcji recyrkulacyjnej.
RO Numai pentru opțiunea de montare cu recirculare.

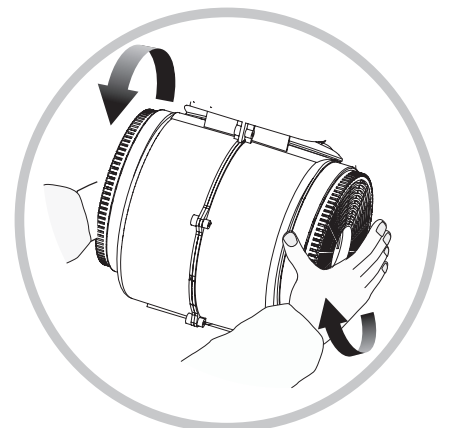
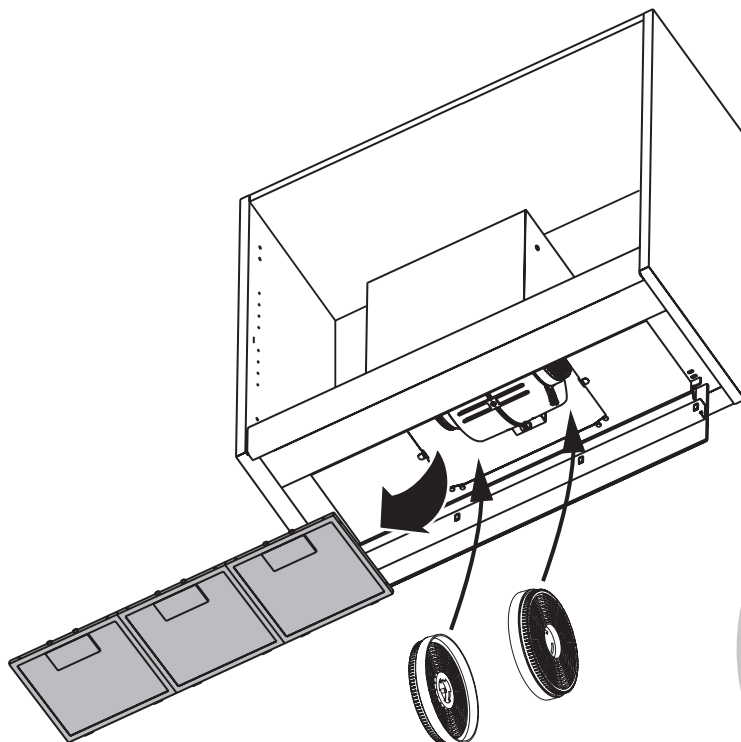
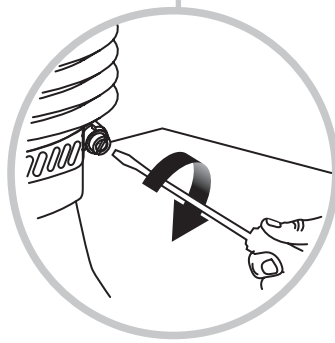
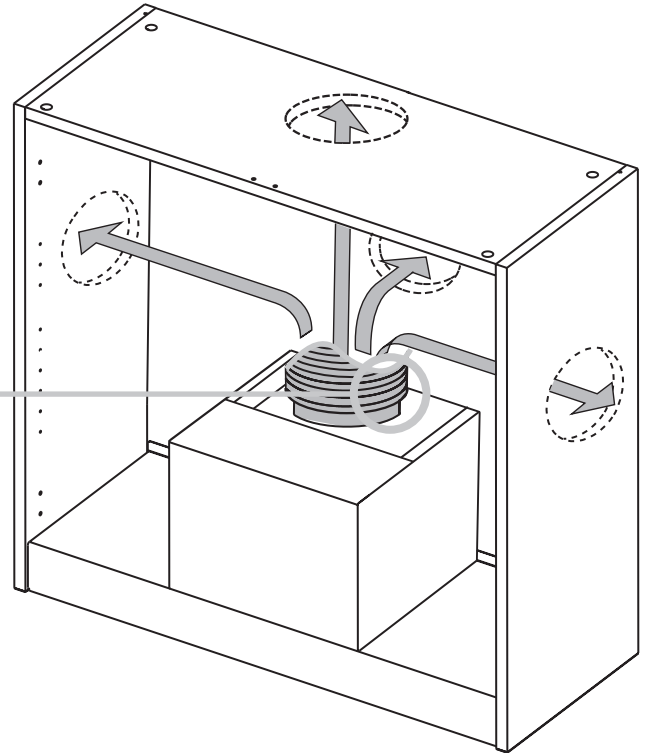
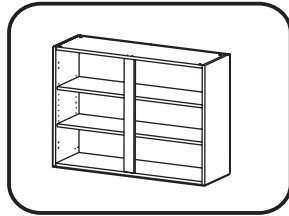

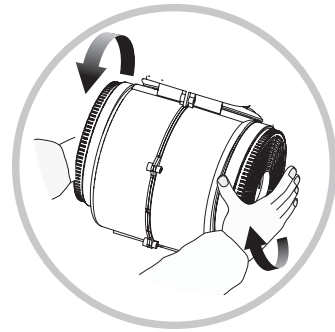
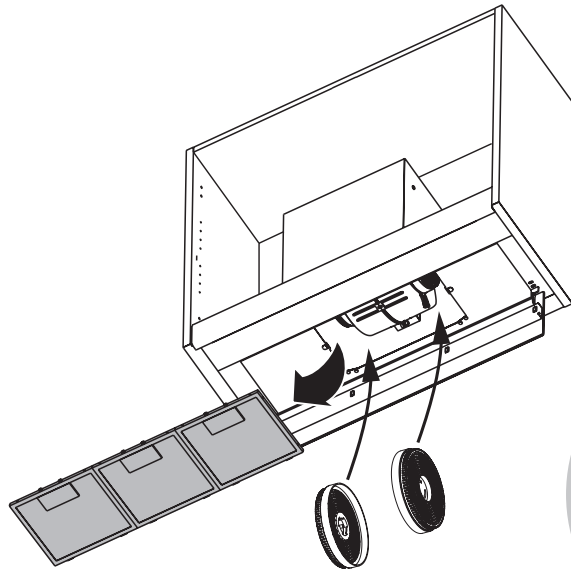
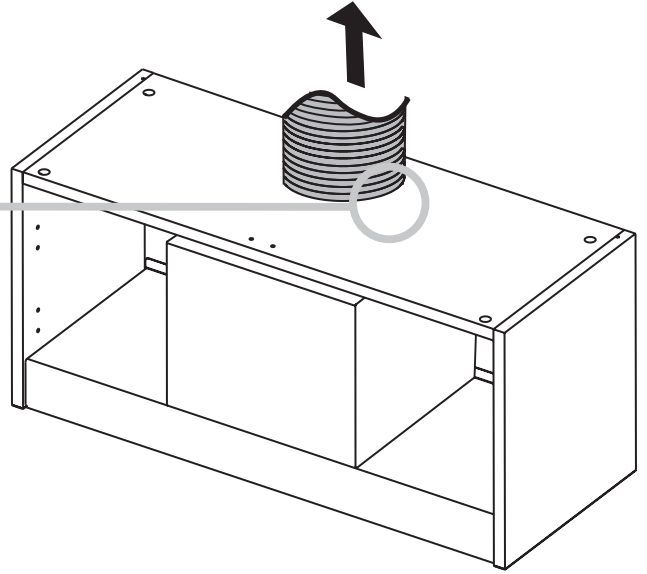
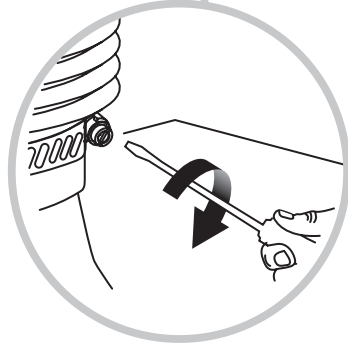
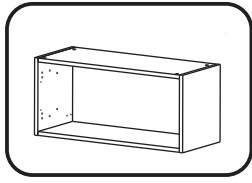

44

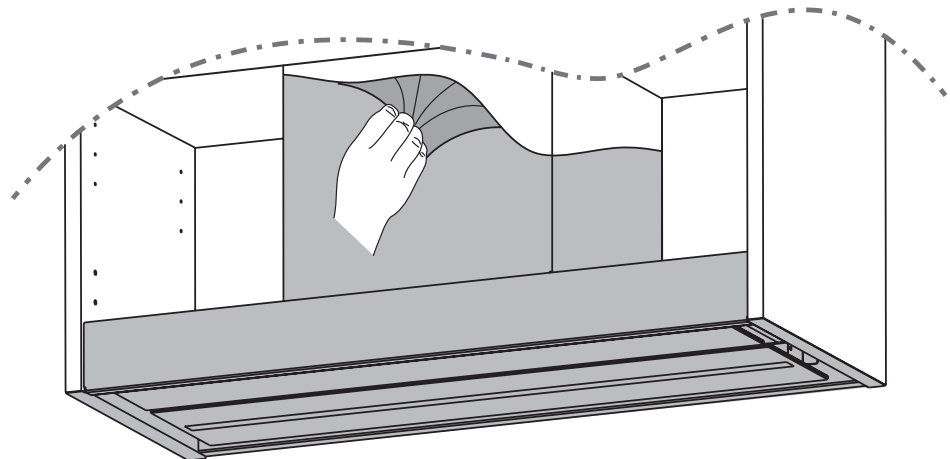



EN Use

PL Użytkowanie

FR Utilisation

RO Utilizare

EN Before you start



WARNING: Read the instructions before using the appliance.

Switch on the appliance at the switched fused connection unit. The appliance is ready for use.

EN Function & Settings

01 Control panel

To obtain the best results from your cooker hood it is recommended that you leave it switched on for a short time after you have finished cooking.

	Timer	
	Fan Boost Function and Speed Increase	
	Hood On/Off	
	LED Display	
	Fan Speed Reduction	
	Light On/Off	
	Movement Sensor	

To Set Up For First Time Use

Once you have turned on the appliance at the switched fused connection unit, all the icons will start to blink white. The hood is now in settings mode.

If you do not want to set up the hood at this stage it can be turned off by pressing the Hood On/Off Icon or alternatively, it will switch off automatically after 30 seconds.



IMPORTANT: Once in settings mode, you can adjust the recirculation, lighting or sensor options in any order. However, all actions must be completed within two minutes.

Setting the Ducted or Recirculation mode

Turn off the power first and within 30 seconds of turning on the mains power again, press the Timer Icon and the Timer Icon will turn blue. The LED display will show the current Ducted or Recirculation mode.

Ducted mode The default setting to extract air to the outside.

Recirculation mode The setting to recirculate the air with carbon filters installed.

To change this option press either or to select the correct mode and then press the Timer Icon to accept the change.



EN Use

PL Użytkowanie

FR Utilisation

RO Utilizare

Setting the Lighting mode



Within 30 seconds of turning on the mains power, press the Light Icon  and the Light Icon will turn blue. The LED display will show the current lighting mode.

Cool light . Default setting for all lights.

Warm light . Optional setting for all lights.

To change these settings press  or  and press the Light Icon  to accept the change.

Setting the Movement Sensor

Within 30 seconds of turning on the mains power, press the Timer and Light Icons together   for 2 seconds to adjust the Movement Sensor. Repeat this process to alter the sensor setting if required. The LED display will show the selected mode.

Sensor enabled  the display will flash for 5 seconds - default setting.



Sensor disabled  the display will remain solid for 5 seconds.



Note: To change any of these settings at a later time, you must switch off the power at the mains outlet first. Wait a few seconds, turn on the power again and adjust as required.

02 General Use

On/Off

1. Touch the Hood On/Off Icon  and the glass panel of the cooker hood will open. The fan will turn on at speed 1 and the light will come on at the last setting used. All icons will be white apart from the Light Icon  which will be blue if the light was already on.

2. Press the On/Off Icon again to turn off the cooker hood; the glass panel will close and the fan will switch off. The light will also turn off automatically after 5 minutes. If you wish to leave the light on for an extended time, manually switch on at the control panel.

Movement Sensor  (if enabled)

You can switch on the cooker hood by passing your hand in front of the Movement Sensor.

Note you cannot turn off the cooker hood using the Movement Sensor, you must touch the Hood On/Off  Icon instead.

Light On/Off

1. Touch the Light Icon to turn on the downlight.



2. To change the brightness of the downlight, touch and hold the Light Icon  until the display shows the brightness sequence. Remove your finger from the Light Icon when the desired brightness is achieved. The sequence runs from L1 to L5 and back to L1 in steps. The selected brightness will flash for a few seconds and revert to the fan speed display.

Fan On/Off and Speed Reduction

1. If the fan motor is set at speeds 2, 3, 4, 5 or P, pressing the Fan Decrease Icon  will reduce the speed by one level at a time. If you press the Fan Decrease Icon  for more than two seconds, the speed will drop to speed 1 from any other level.

2. If the fan motor is set at speed 1, pressing the Fan Decrease Icon  will result in the motor switching off. However the downlight will remain on (if enabled) and the display will show the current brightness level.

Boost Function and Speed Increase

If the fan motor is set at speeds 1, 2, 3, 4 or 5, pressing the Fan Increase Icon  will increase the speed by one level at a time. If you press the Fan Increase Icon  for more than two seconds, the speed will increase to full power from any level and the display will flash 'P'.







NOTE: Full power or Boost (P) only operates for five minutes maximum to conserve energy and the fan speed will automatically drop to speed level 5 after this time.

Setting the Timer

1. When the fan motor is on and the Timer Icon  is pressed the icon will flash blue and the display will show the current fan speed.

2. The chosen speed level will remain in use for five minutes before dropping down to the next lowest speed. This speed will remain in operation for two minutes before dropping down again. This will be repeated every two minutes unless the speed is already at level 1 and then the fan will turn off. If the light is already on, this will also be turned off.

3. Pressing the Fan Decrease Icon  or Fan Increase Icon  during a current timer program will restart the countdown process again with the first five minute cycle.

4. If the Timer Icon  is pressed again during a current timer program, the cycle will be cancelled. The Timer Icon  will revert to white and the current fan speed will remain on indefinitely

5. The maximum timer program cycle is 15 minutes: 5 minutes on P and then 2 minutes each on speed 5 down to speed 1.



EN Controlling a GoodHome cooker hood remotely



IMPORTANT: This section is only applicable if you have purchased a GoodHome induction hob.



The process for connecting the hood to the hob happens in three stages:

- A) Configure the hob to transmit a radio frequency signal.
- B) Configure the hood to receive this signal.
- C) Lock the connectivity between the two appliances and complete the pairing process.

STAGE A

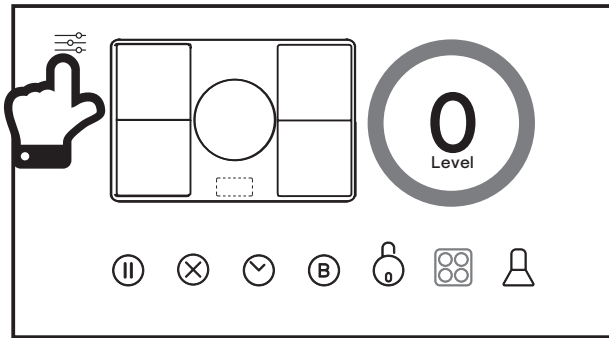
1. The induction hob must be switched on and showing the Home Screen display before proceeding.



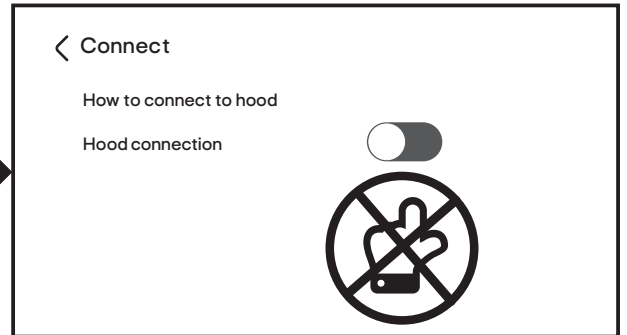
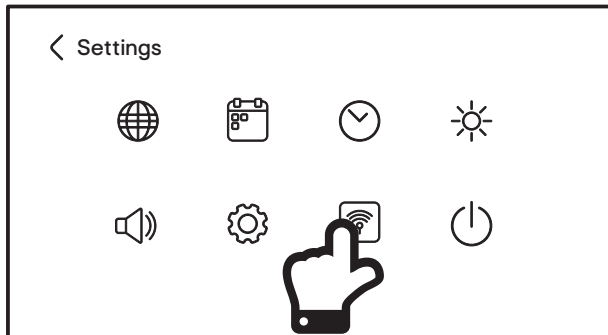

2. Touch the Main Menu key  on the Home Screen to take you to the Settings menu. Touch the Connect Icon  to initiate the pairing sequence and transmit a radio frequency signal from the hob. Do not touch the Hood connection button on the hob yet!



IMPORTANT: To proceed with the connectivity operation, the hood must be switched off at the mains power switch. Turn on the hood again and complete Stage B and C within two minutes. If connection is not successful, turn off the hood again, wait for one minute and try again.

STAGE B

1. When the hood is first switched on, the control panel will blink white in Settings mode.
2. Touch the Fan Speed Increase icon  and Fan Decrease Icon  together for two seconds on the hood control panel and both icons will turn blue and the Automatic symbol "A" will appear in the display. The hood is configured to receive the signal.

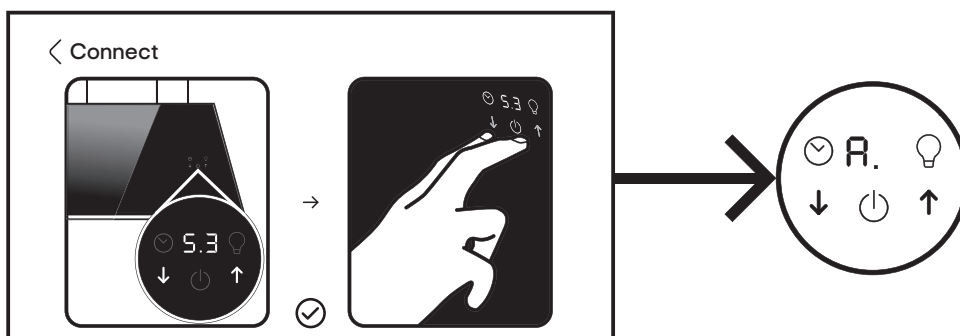



STAGE C

1. Now touch the Hood connection button  on the hob and it will turn blue.

2. The hob will briefly show a connected message to indicate that the hob is now locked with the hood and the pairing process is complete. The hood will also show the double "A" symbols in its control panel to indicate pairing is complete.

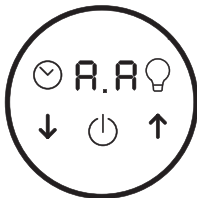
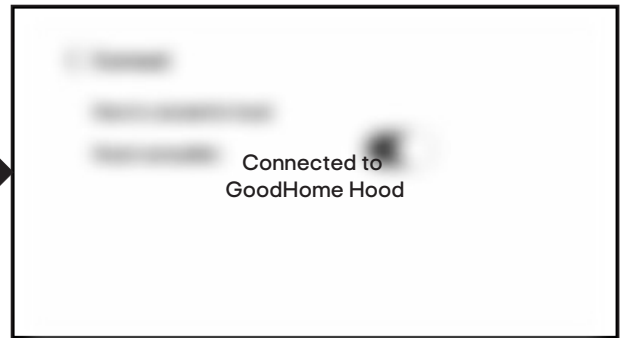
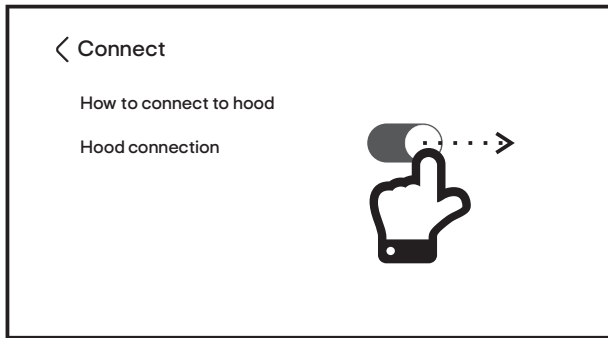

IMPORTANT: Once the hob and hood are paired and locked together you can now choose to use your GoodHome appliances in three ways, Independent Control, Semi-Automatic Control and Automatic Control.

1. Independent Control - The Hood connection button on the hob is OFF and you can operate the hood's fan and extraction manually as required independently of any settings on the hob.

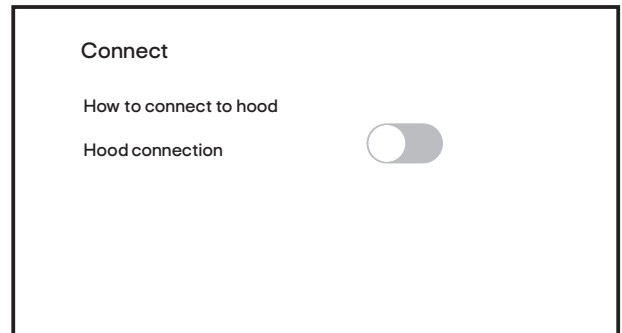

2. Semi-Automatic Control - The Hood connection button on the hob is ON and you can control the hood's fan and extraction manually from the 360 Master Control Key on the hob control panel.

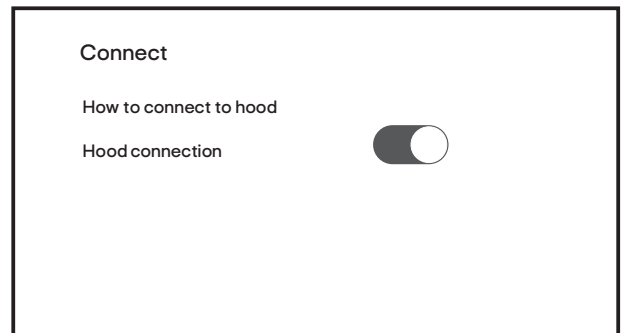

3. Automatic Control - The Hood connection button on the hob is ON and the hob will control the hood's fan and extraction based upon the power levels in use on the hob.

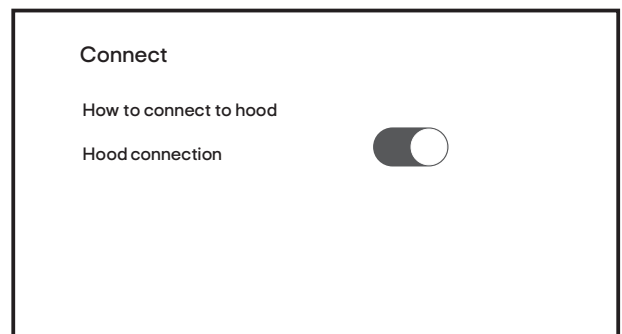



NOTE: You do not need to complete the pairing process again if you switch off the Hood connection on the hob. The link is stored in memory and will be reactivated once you have switched Hood connection back on.

NOTE: If you touch the Cooker Hood Control Panel Key before connectivity is complete you will see this message on screen:

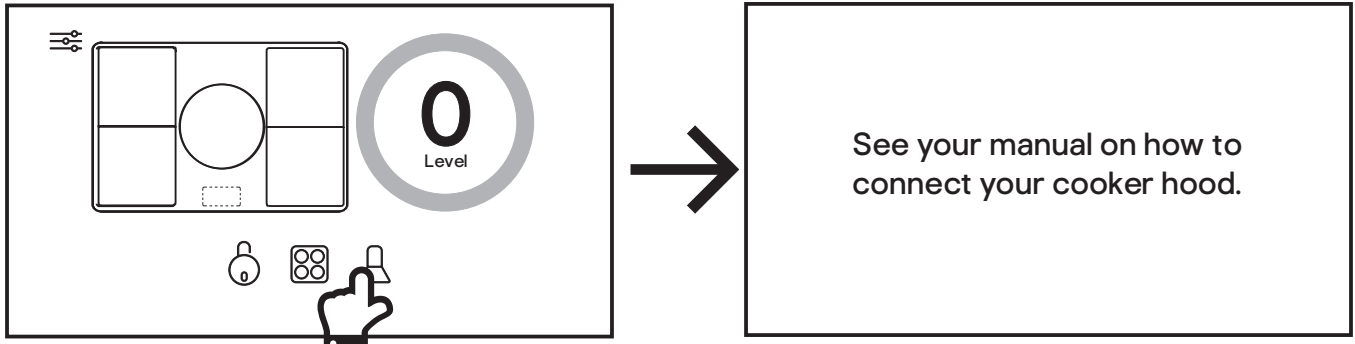

01 Controlling the cooker hood from your hob

Ensure the hob and hood connectivity has been completed and the Hood connection button is ON!

1. From the hob Home Screen, touch the Cooker Hood Icon  to access the Cooker Hood Control Panel, and the icon will turn blue.

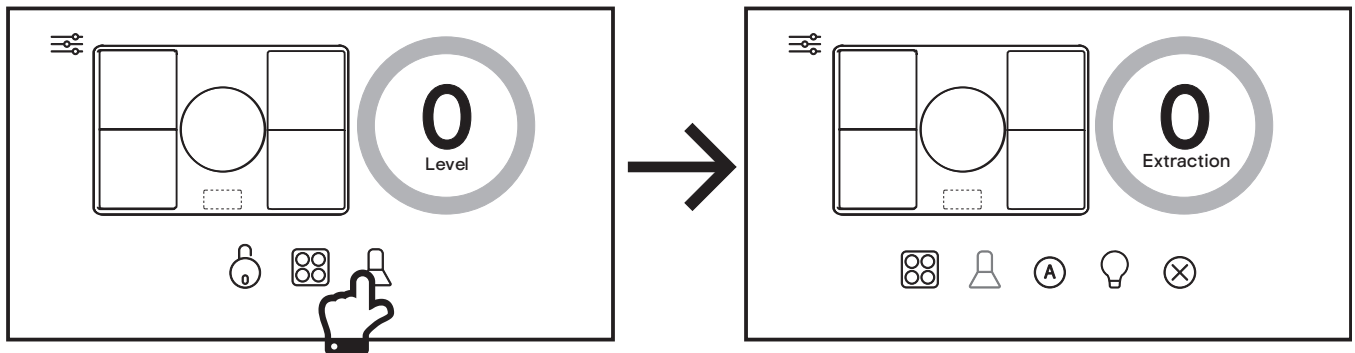

2. To control the extraction rate of the hood manually, rotate or touch the 360° Master Control Key from 0-5 and B for boost. The Hood On/Off Icon on the hood will alternately flash blue and white. This is Semi-Automatic Control.

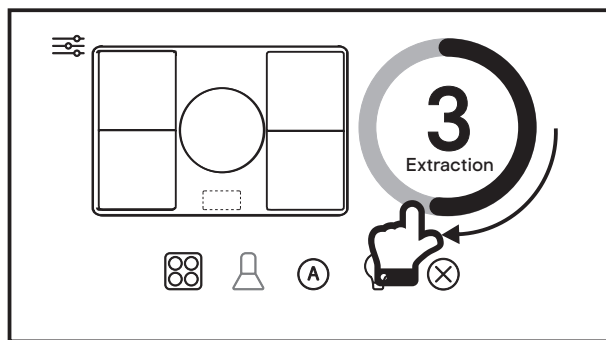

3. To control the extraction rate of the hood automatically, touch the Auto Extraction Control icon  on the hob. The icon will turn green in colour and the hob will now automatically adjust the extraction rate of the hood according to the power output of the hob. See the table below for details. This is Automatic Control.

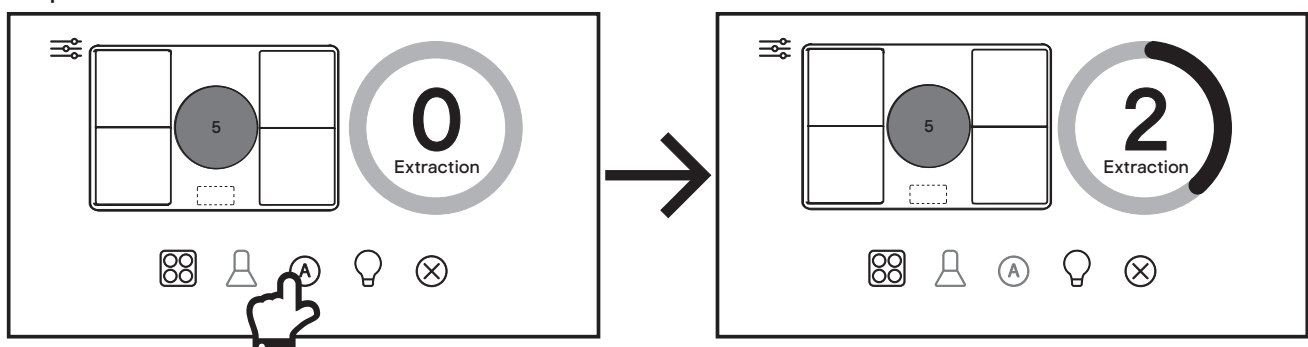



EN Use

PL Użytkowanie

FR Utilisation

RO Utilizare



IMPORTANT: The extraction rate of the hood will vary based upon the total power output selected on the hob, as shown in the table below.

Speed Level of the Hood	Combined Power Output of the Hob
Speed 2	This speed will be selected when the combined power output of all zones is 8 or less. For example Zone A is on 3 and Zone B is on 4.
Speed 4	This speed will be selected when the combined power output of all zones is between 9 and 24. For example Zone A is on 3, Zone B is on 4 and Zone D is on 6.
Speed 5	This speed will be selected when the combined power output of all zones is between 25 and 32. For example Zone A is on 9, Zone B is on 8, Zone D is 8 and Zone E is 4.
Speed P - Boost	This speed will be selected when the combined power output of all zones is greater than 32. For example Zone A is on 8, Zone B is on 7, Zone D is on 9, Zone E is on 6 and Zone F is on 6.

Note: Speed 1 and Speed 3 on the hood are not available when using this function.



IMPORTANT: Please note that you CANNOT override the current status of the hood from its control panel when you are in Automatic Control. If you attempt to switch the hood off, the hob will turn the hood back on!

If you wish to manually control the hood again and revert to Independent Control, disable the Auto Extraction Control icon and switch off the Hood Connection button on the hob.

In both automatic modes, and if none of the hob cooking zones are active, the hood will automatically enter Timer Mode after one minute of inactivity and will step down through the power levels one at a time to turn off the hood after a short period. See the Timer section of the hood manual for more details.

NOTE: Whilst the hob is still switched on the On/Off Icon on the hood will blink, but if the hob is switched off during Timer Mode, the Timer Icon on the hood will blink instead and step down through the power levels to turn off the hood as before.

02 Changing the lamp colour and brightness of the cooker hood from the hob

1. Select the Cooker Hood Control Panel from the Main Menu. Touch the Lighting Control Icon  to select the brightness control function.

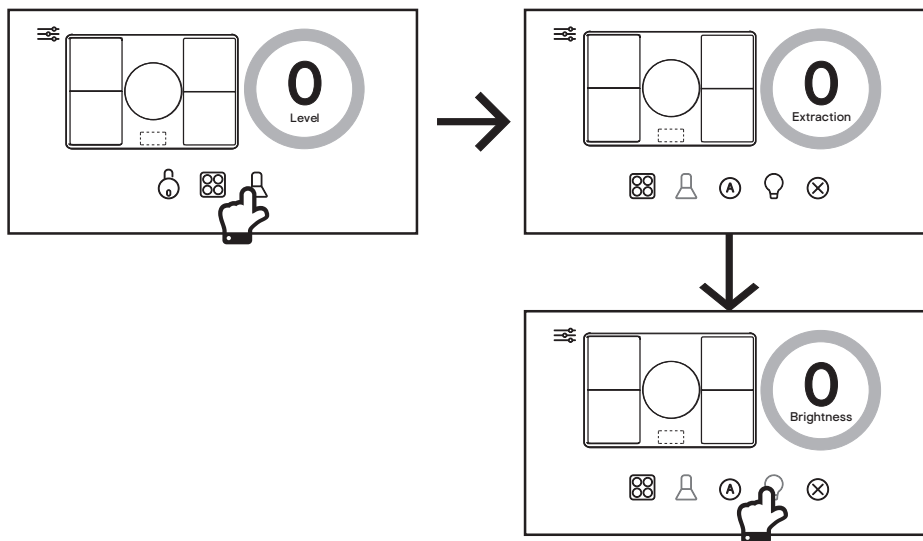



EN Use

PL Użytkowanie

FR Utilisation

RO Utilizare

2. Adjust the brightness level by rotating the 360° Master Control Key between 0-5.

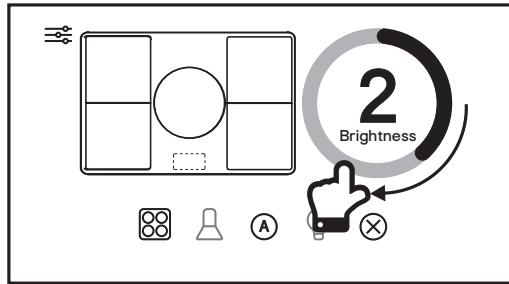

3. You can also adjust the lamp colour temperature by touching the Lighting Control Icon  in this sequence:

(a) Blue - Cool White (default).

(b) Orange - Warm White.

Note: You can turn off the lamp by touching the Stop Icon .

There will be a slight delay when transmitting this signal to the hood.

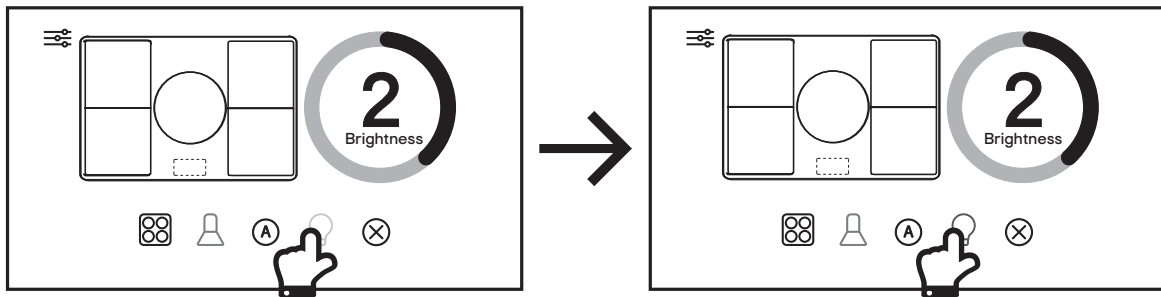

FR Avant de commencer









AVERTISSEMENT : lire les instructions avant d'utiliser l'électroménager.

Mettre l'appareil en marche sur l'unité de raccordement avec fusibles et interrupteur. L'appareil est prêt à l'emploi.

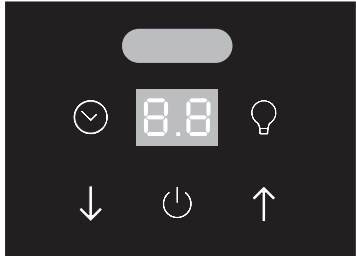
FR Fonctions et réglages

01 Panneau de contrôle

Pour obtenir les meilleurs résultats de votre hotte Il est recommandé de la laisser allumée pendant quelques instants une fois la cuisson terminée.

	Minuterie	
	Fonction Boost du ventilateur et augmentation de vitesse	
	Marche/arrêt de la hotte	
8.8	Affichage LED	
	Réduction de vitesse du ventilateur	
	Activation/désactivation de l'éclairage	
	Capteur de mouvement	



EN Use

PL Użytkowanie

FR Utilisation

RO Utilizare

43

Configuration pour la première utilisation

Une fois l'électroménager activé sur l'unité de raccordement avec fusibles et interrupteur, toutes les icônes se mettent à clignoter d'une couleur blanche. La hotte est maintenant en mode de réglage.

Si la hotte n'est pas à régler à ce stade, elle peut être éteinte en appuyant sur l'icône de marche/arrêt  ou elle s'éteint automatiquement après 30 secondes.



IMPORTANT : une fois en mode de réglage, il est possible de régler les options de recyclage, d'éclairage ou de capteur dans n'importe quel ordre. Cependant, toutes les actions doivent être exécutées dans un délai de deux minutes.

Réglage du mode de recyclage ou d'extraction

Commencer par couper l'alimentation. Dans un délai de 30 secondes après la remise sous tension, appuyer sur l'icône  de minuterie, qui s'affiche alors en bleu. L'affichage LED indique le mode de recyclage ou d'extraction actuel.

Mode d'extraction . Paramètre par défaut pour évacuer l'air vers l'extérieur.

Mode de recyclage . Paramètre pour recycler l'air grâce aux filtres à charbon installés.

Pour changer cette option, appuyer sur  ou  pour sélectionner le mode souhaité, puis appuyer sur l'icône de minuterie pour accepter la modification.

Réglage du mode d'éclairage

Dans les 30 secondes suivant la mise sous tension, appuyer sur l'icône  d'éclairage qui s'affiche alors en bleu. L'affichage LED indique le mode d'éclairage actuel.

Lumière froide . Réglage par défaut pour toutes les lumières.

Lumière chaude . Réglage en option pour toutes les lumières.

Pour modifier ces réglages, appuyer sur  ou  et appuyer sur l'icône d'éclairage pour accepter la modification.

Réglage du capteur de mouvement

Dans les 30 secondes suivant la mise sous tension, appuyer simultanément sur les icônes de minuterie et d'éclairage pendant 2 secondes pour régler le capteur de mouvement. Répéter l'opération pour modifier le réglage du capteur si nécessaire. L'affichage LED indique le mode sélectionné.



Capteur activé . L'affichage clignote pendant 5 secondes (réglage par défaut).

Capteur désactivé . L'affichage reste fixe pendant 5 secondes.

Remarque : pour modifier ces paramètres ultérieurement, couper d'abord le courant au niveau de la prise de courant. Attendre quelques secondes, remettre sous tension et régler si nécessaire.

02 Utilisation générale

Marche/arrêt

1. Appuyer sur l'icône de marche/arrêt  de la hotte. Le panneau de verre de la hotte aspirante s'ouvre. Le ventilateur s'allume en vitesse 1 et l'éclairage s'allume selon le dernier réglage utilisé. Toutes les icônes  sont blanches, à l'exception de l'icône d'éclairage qui est bleue si l'éclairage était déjà allumé.

2. Appuyer sur l'icône de marche/arrêt  pour arrêter la hotte ; le panneau de verre se ferme et le ventilateur s'éteint. La lumière s'éteint également automatiquement après 5 minutes. Pour laisser la lumière allumée pendant une longue période, mettre l'éclairage en marche manuellement via le panneau de commande.

Capteur de mouvement  (si activé)

Il est possible d'allumer la hotte aspirante en passant la main devant le capteur de mouvement. Remarque : la hotte aspirante ne peut pas s'éteindre à l'aide du capteur de mouvement ; appuyer sur l'icône de marche/arrêt  de la hotte à la place.

Activation/désactivation de l'éclairage

1. Appuyer sur l'icône d'éclairage pour allumer le spot.

2. Pour modifier la luminosité du spot, appuyer longuement sur l'icône  d'éclairage jusqu'à ce que l'écran affiche la séquence de luminosité. Retirer le doigt de l'icône d'éclairage quand la luminosité souhaitée est obtenue. La séquence défile de L1 à L5, puis revient à L1. La luminosité sélectionnée clignote pendant quelques secondes, puis revient à l'affichage de la vitesse du ventilateur.

Activation/désactivation du ventilateur et réduction de la vitesse

1. Si le moteur du ventilateur est réglé sur la vitesse 2, 3, 4, 5 ou P, appuyer sur l'icône de réduction de vitesse du ventilateur pour réduire la vitesse un niveau à la fois. Appuyer sur l'icône de réduction de vitesse du ventilateur pendant plus de deux secondes fait chuter la vitesse à la vitesse 1, quelle que soit la vitesse précédemment définie.



EN Use

PL Użytkowanie

FR Utilisation

RO Utilizare

2. Si le moteur du ventilateur est réglé sur la vitesse 1, appuyer sur l'icône de réduction de vitesse du ventilateur entraîne la mise hors tension du moteur. Cependant, le spot reste allumé (si activé) et l'affichage indique le niveau de luminosité actuel.

Fonction Boost et augmentation de la vitesse ↑

Si le moteur du ventilateur est réglé sur la vitesse 1, 2, 3, 4 ou 5, appuyer sur l'icône d'augmentation de vitesse du ventilateur pour augmenter la vitesse un niveau à la fois. Appuyer sur l'icône d'augmentation de vitesse du ventilateur pendant plus de deux secondes active la pleine puissance, quelle que soit la vitesse précédemment définie, et « P » clignote sur l'affichage.



REMARQUE : les options Full power (pleine puissance) ou Boost (P) ne fonctionnent que pendant cinq minutes maximum pour économiser l'énergie. La vitesse du ventilateur chute automatiquement au niveau de vitesse 5 après cette durée.

Réglage de la minuterie ⏸

1. Lorsque le moteur du ventilateur est allumé et que l'icône ⏸ de minuterie est activée, l'icône clignote en bleu et l'affichage indique la vitesse actuelle du ventilateur.
2. Le niveau de vitesse choisi est maintenu pendant cinq minutes avant de ralentir jusqu'à la vitesse inférieure. Cette vitesse est maintenue pendant deux minutes avant de ralentir à nouveau. Ce procédé se répète toutes les deux minutes, à moins que la vitesse soit déjà au niveau 1, puis le ventilateur s'éteint. Si l'éclairage est allumé, il s'éteint également.
3. En appuyant sur l'icône de réduction de vitesse du ventilateur ou sur l'icône d'augmentation de vitesse du ventilateur alors qu'un programme de minuterie est en cours, le processus de compte à rebours redémarre avec le premier cycle de cinq minutes.
4. Si l'icône ⏸ de minuterie est à nouveau activée au cours d'un programme de minuterie en cours, le cycle est annulé. L'icône ⏸ de minuterie redevient blanche et la vitesse actuelle du ventilateur reste indéfiniment activée.
5. Le cycle maximum du programme de minuterie est de 15 minutes : 5 minutes sur P et 2 minutes sur chaque vitesse, de la vitesse 5 jusqu'à la vitesse 1.

FR Commande à distance d'une hotte aspirante GoodHome



IMPORTANT : cette section est seulement applicable si vous avez acheté une plaque de cuisson à induction GoodHome.

Le processus de connexion de la hotte à la plaque de cuisson comprend trois étapes :

- A) Configuration de la plaque de cuisson pour la transmission d'un signal de fréquence radio.
- B) Configuration de la hotte pour la réception de ce signal.
- C) Verrouillage de la connexion entre les deux appareils et jumelage.

ÉTAPE A

1. Avant de continuer, la plaque de cuisson à induction doit être allumée et doit afficher l'écran d'accueil.

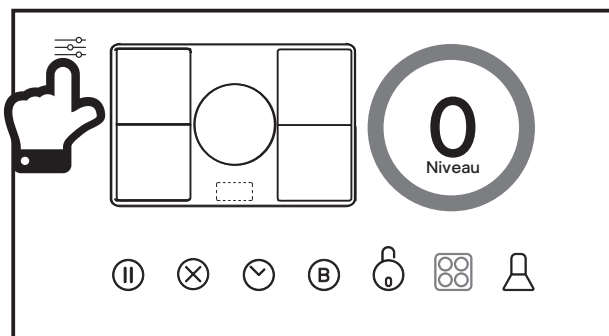



EN Use

PL Użytkowanie

FR Utilisation

RO Utilizare

2. Appuyer sur la touche de menu ☰ principal sur l'écran d'accueil pour accéder au menu des réglages. Appuyer sur l'icône de connexion 📶 pour lancer la séquence de jumelage et transmettre un signal de fréquence radio depuis la plaque de cuisson. Pour l'instant, ne pas toucher le bouton de connexion de la hotte sur la plaque de cuisson !

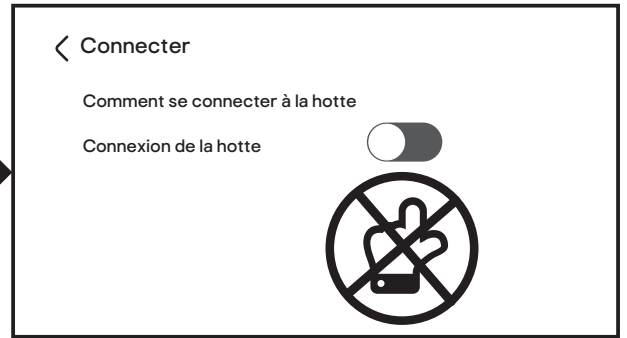
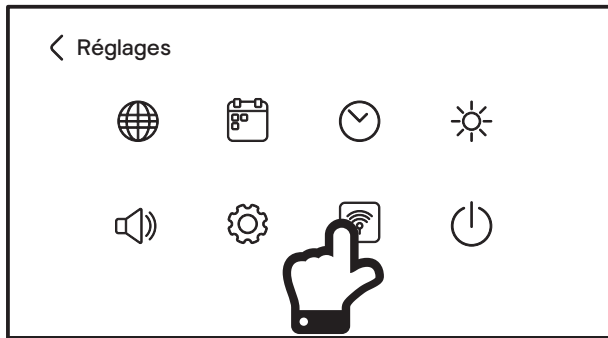

IMPORTANT : pour procéder à l'opération de connexion, la hotte doit être désactivée à l'aide de l'interrupteur d'alimentation. Remettre la hotte sous tension et réaliser les étapes B et C dans les deux minutes. Si la connexion n'aboutit pas, remettre la hotte hors tension, attendre une minute et essayer à nouveau.

ÉTAPE B

1. Lorsque la hotte est mise sous tension pour la première fois, le panneau de commande clignote en blanc en mode de réglage.
2. Appuyer simultanément sur l'icône d'augmentation de vitesse du ventilateur et sur l'icône de réduction de vitesse du ventilateur pendant deux secondes sur le panneau de commande de la hotte. Les deux icônes deviennent bleues et le symbole automatique « A » s'affiche à l'écran. La hotte est désormais configurée pour recevoir le signal.

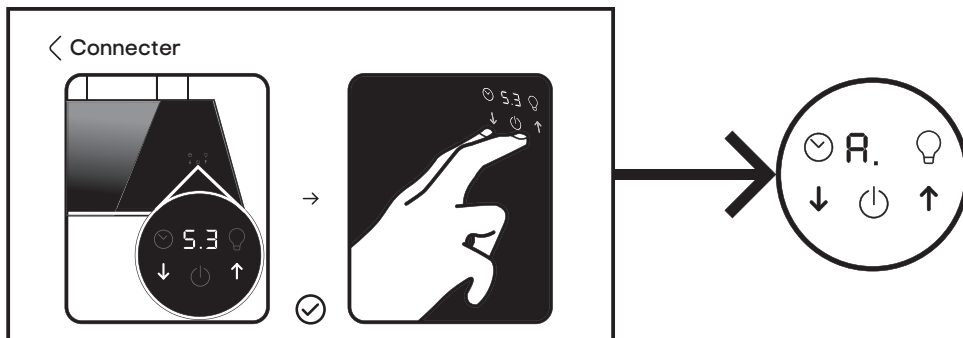

ÉTAPE C

1. Appuyer maintenant sur le bouton de connexion 📶 de la hotte sur la plaque de cuisson. Il devient bleu.
2. La plaque de cuisson affiche brièvement un message de connexion pour indiquer que la plaque de cuisson est maintenant connectée à la hotte et que le processus de jumelage est terminé. Le panneau de commande de la hotte affiche également le symbole « A » en double pour indiquer que le jumelage est terminé.

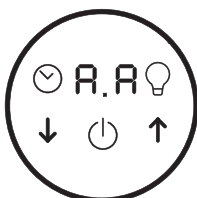
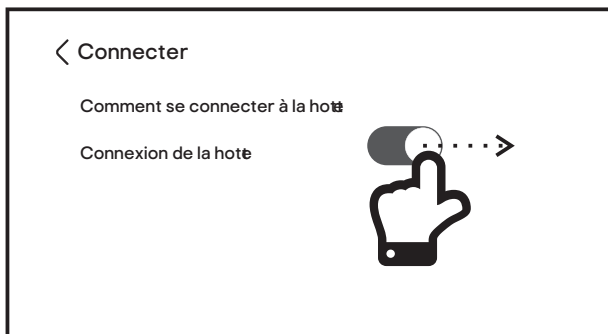



EN Use

PL Użytkowanie

FR Utilisation

RO Utilizare



IMPORTANT : une fois la plaque de cuisson et la hotte jumelées et connectées l'une à l'autre, vous pouvez choisir d'utiliser vos électroménagers GoodHome de trois façons : commande indépendante, commande semi-automatique ou commande automatique.

1. **Commande indépendante** : le bouton de connexion de la hotte sur la plaque de cuisson est désactivé. Le ventilateur et l'extraction de la hotte peuvent être utilisés manuellement selon les besoins, indépendamment des réglages de la plaque de cuisson.

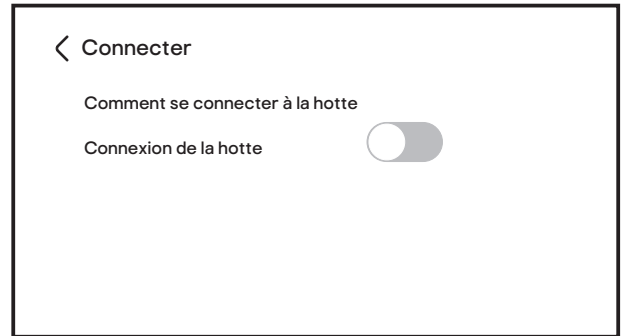

2. **Commande semi-automatique** : le bouton de connexion de la hotte sur la plaque de cuisson est activé. Le ventilateur et l'extraction de la hotte peuvent être contrôlés grâce à la touche principale de commande 360° sur le panneau de commande de la plaque de cuisson.

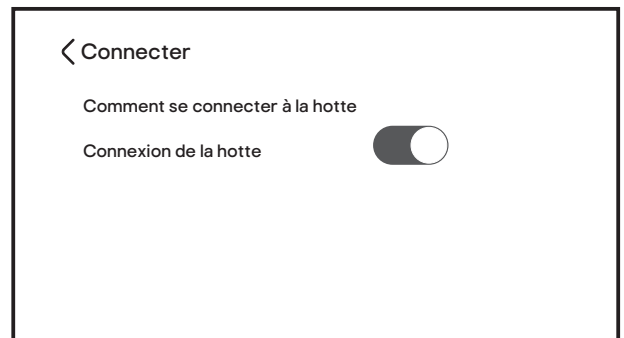

3. **Commande automatique** : le bouton de connexion de la hotte sur la plaque de cuisson est activé. La plaque de cuisson commande le ventilateur et l'extraction de la hotte selon les niveaux de puissance utilisés sur la plaque de cuisson.

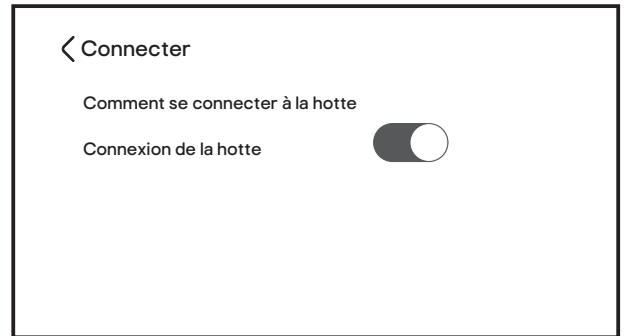

REMARQUE : il n'est pas nécessaire de procéder à nouveau au jumelage si la connexion de la hotte sur la plaque de cuisson est désactivée. La liaison est enregistrée et sera réactivée une fois la connexion de la hotte activée.

REMARQUE : si l'on appuie sur la touche du panneau de commande de la hotte aspirante avant que la connexion ne soit terminée, le message suivant s'affiche à l'écran :

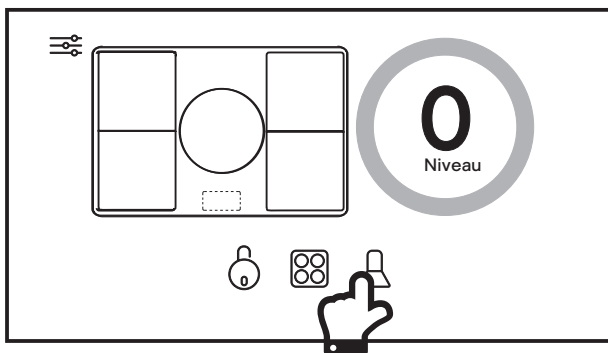

Consulter le manuel pour savoir comment connecter votre hotte.



01 Commande de la hotte aspirante depuis la plaque de cuisson

Vérifier que la connexion de la plaque de cuisson et de la hotte s'est correctement terminée et que le bouton de connexion de la hotte est activé.

1. À partir de l'écran d'accueil de la plaque de cuisson, appuyer sur l'icône Hotte aspirante pour accéder au panneau de commande de la hotte aspirante. L'icône  devient bleue.

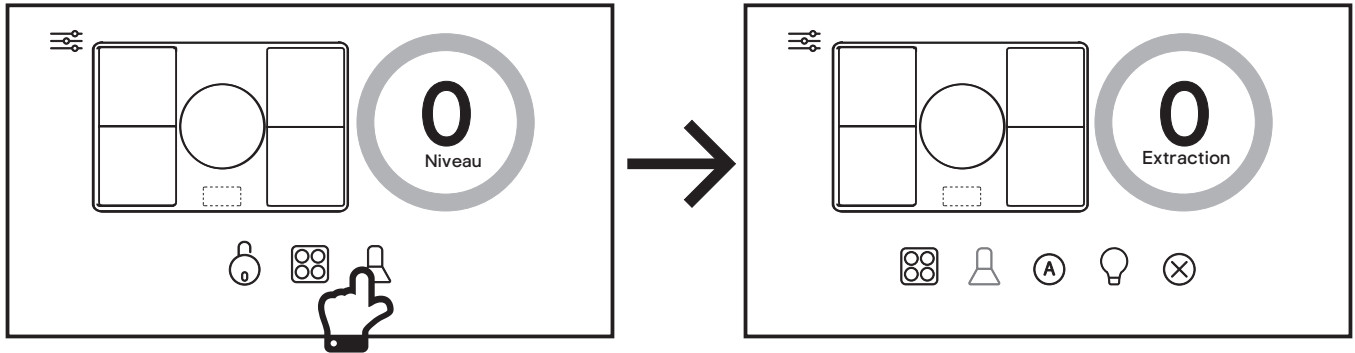

2. Pour commander manuellement le taux d'extraction de la hotte, choisir un réglage de 0 à 5 en tournant ou touchant la touche principale de commande 360° ou en choisissant B pour la fonction Boost. L'icône de marche/arrêt  de la hotte clignote en bleu et blanc. Il s'agit de la commande semi-automatique.

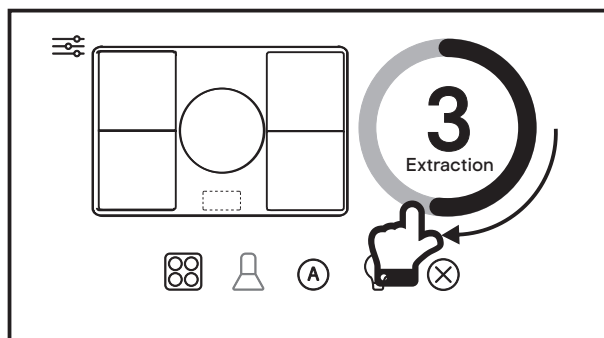

3. Pour commander automatiquement le taux d'extraction de la hotte, appuyer sur l'icône de commande d'extraction automatique  sur la plaque de cuisson. L'icône devient verte et la plaque de cuisson règle automatiquement le taux d'extraction en fonction de la puissance de fonctionnement de la plaque. Consulter le tableau ci-dessous pour en savoir plus. Il s'agit de la commande automatique.

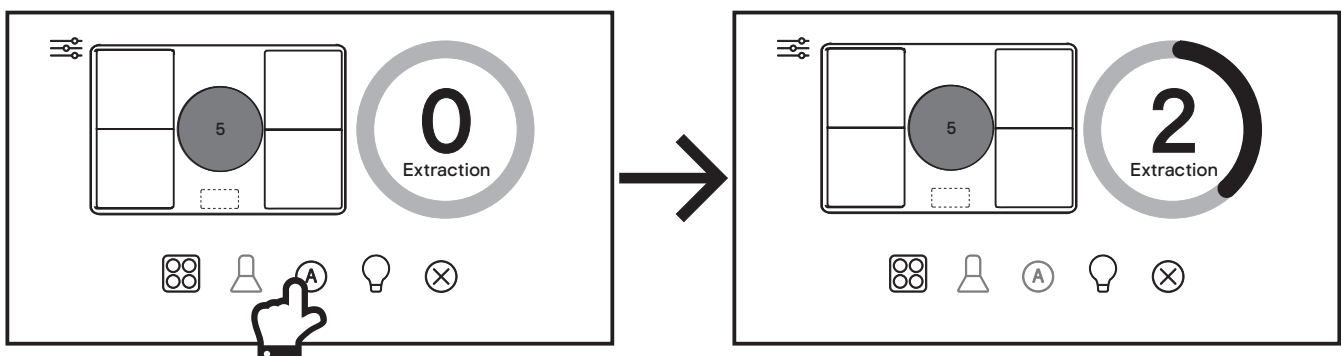

IMPORTANT : le taux d'extraction de la hotte varie en fonction de la puissance totale sélectionnée sur la plaque de cuisson, comme indiqué dans le tableau ci-dessous.



Niveau de vitesse de la hotte	Puissance de sortie combinée de la plaque de cuisson
Vitesse 2	Cette vitesse est sélectionnée si la puissance combinée de toutes les zones est de 8 ou moins. Par exemple, la zone A est sur 3 et la zone B est sur 4.
Vitesse 4	Cette vitesse est sélectionnée si la puissance combinée de toutes les zones est comprise entre 9 et 24. Par exemple, la zone A est sur 3, la zone B est sur 4 et la zone D est sur 6.
Vitesse 5	Cette vitesse est sélectionnée si la puissance combinée de toutes les zones est comprise entre 25 et 32. Par exemple, la zone A est sur 9, la zone B est sur 8, la zone D est sur 8 et la zone E est sur 4.
Vitesse P - Boost	Cette vitesse est sélectionnée si la puissance combinée de toutes les zones est supérieure à 32. Par exemple, la zone A est sur 8, la zone B est sur 7, la zone D est sur 9, la zone E est sur 6 et la zone F est sur 6.

Remarque : la vitesse 1 et la vitesse 3 sur la hotte ne sont pas disponibles lors de l'utilisation de cette fonction.



IMPORTANT : veuillez noter que vous NE pouvez PAS neutraliser l'état actuel de la hotte à partir de son panneau de commande lorsque vous êtes en mode de commande automatique. En cas de tentative d'extinction de la hotte, la plaque de cuisson rallume la hotte.

Pour commander la hotte manuellement et revenir à une commande indépendante, désactiver l'icône de commande d'extraction automatique et couper la connexion de la hotte à la plaque de cuisson via le bouton correspondant sur la plaque.

Avec les modes automatiques, et si aucune des zones de cuisson de la plaque de cuisson n'est activée, la hotte entre automatiquement en mode minuterie après une minute d'inactivité et réduit les niveaux de puissance un à la fois pour désactiver la hotte après une courte période. Voir la section Minuterie du manuel de la hotte pour en savoir plus.

REMARQUE : si la plaque de cuisson est toujours allumée, l'icône de marche/arrêt  de la hotte clignote. En revanche, si la plaque de cuisson est éteinte pendant le mode de minuterie, l'icône de minuterie sur la hotte clignote à la place et les niveaux de puissance sont réduits pour éteindre la hotte normalement.

02 Changement de la couleur et de la luminosité de la lampe de la hotte aspirante à partir de la plaque de cuisson

1. Sélectionner le panneau de commande de la hotte aspirante à partir du menu principal. Appuyer sur l'icône  de commande d'éclairage pour sélectionner la fonction de commande de luminosité.

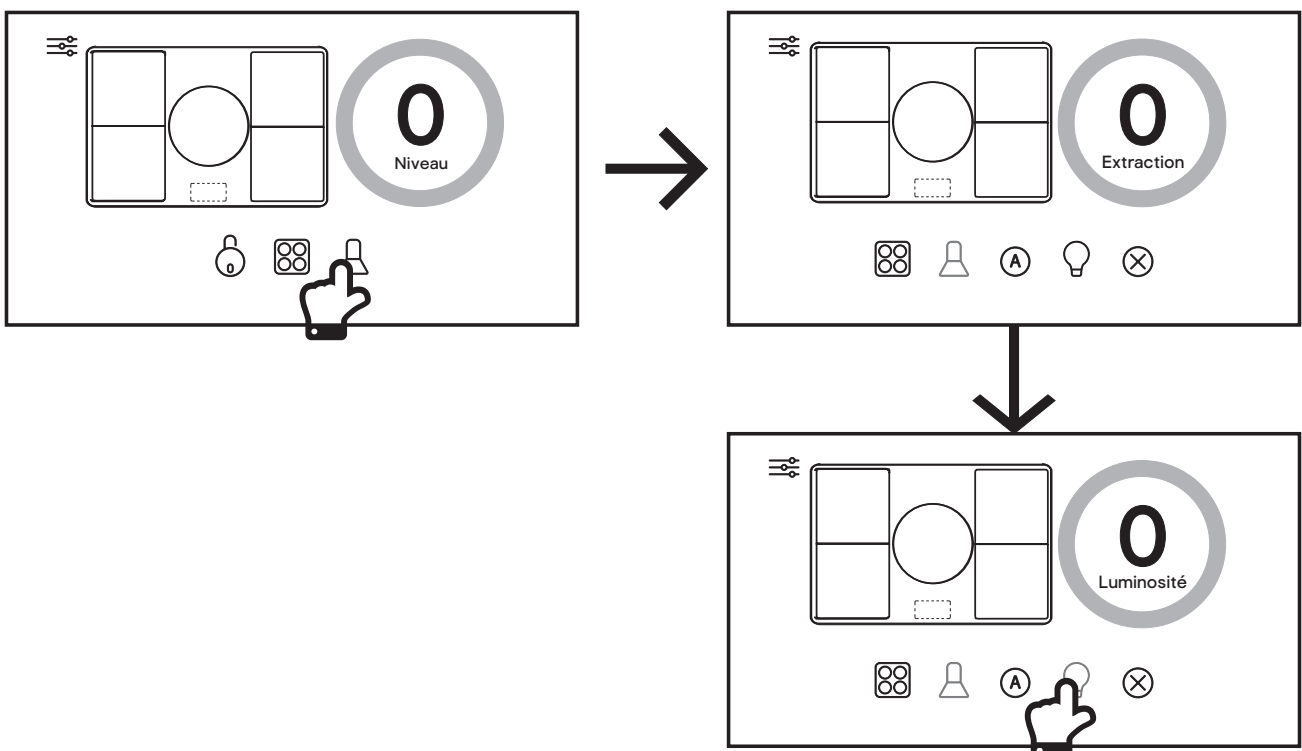



EN Use

PL Użytkowanie

FR Utilisation

RO Utilizare

2. Régler le niveau de luminosité en tournant la touche de commande principale 360° entre 0 et 5.

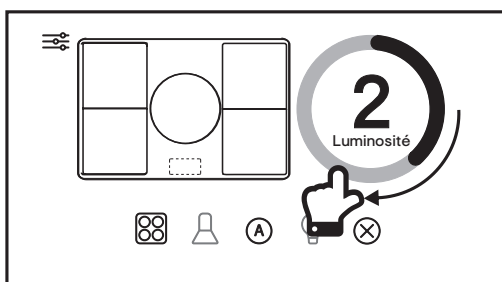

3. La température de couleur de la lampe peut également être réglée en appuyant sur l'icône  de commande d'éclairage dans l'ordre suivant :

(a) Bleu - blanc froid (par défaut).

(b) Orange - blanc chaud.

Remarque : la lampe peut être désactivée en appuyant sur l'icône d'arrêt .

Il y aura un léger retard lors de la transmission de ce signal à la hotte.

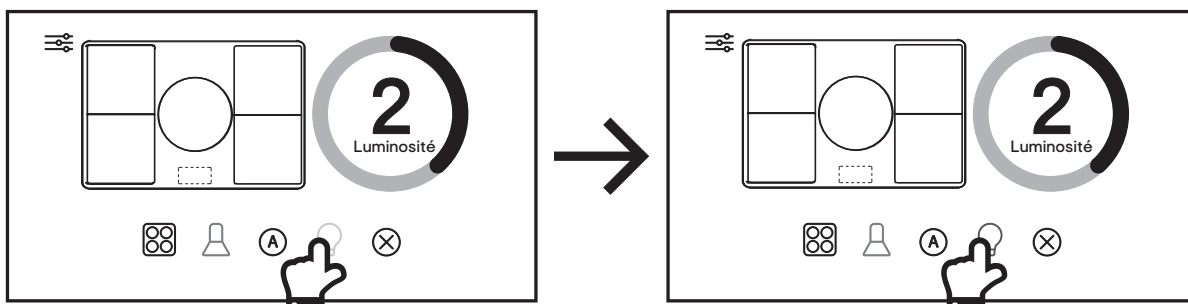



PL Przed rozpoczęciem użytkowania



OSTRZEŻENIE: Przed rozpoczęciem korzystania z urządzenia zapoznać się z instrukcją obsługi.

Włączyć urządzenie za pomocą zestawu wyłącznika z bezpiecznikiem. Urządzenie jest gotowe do użytku.

PL Funkcje i ustawienia

01 Panel sterowania

Aby uzyskać najlepsze rezultaty w okapie kuchennym! Zaleca się pozostawienie włączonego urządzenia na krótki czas po zakończeniu gotowania.

	Timer	
	Funkcja podwyższenia mocy wentylatora i zwiększenia prędkości	
	Okap wł./wył.	
	Wyświetlacz LED	
	Zmniejszanie prędkości wentylatora	
	Włączanie/wyłączanie oświetlenia	
	Czujnik ruchu	

Konfiguracja przed pierwszym użyciem

Po włączeniu urządzenia za pomocą przełączanego złącza z bezpiecznikiem wszystkie ikony zaczną migać na biało. Okap pracuje teraz w trybie ustawień.

Jeśli na tym etapie nie chcesz konfigurować okapu, można go wyłączyć, naciskając ikonę włączania/wyłączania okapu lub wyłączy się on automatycznie po upływie 30 sekund.



WAŻNE: W trybie ustawień można regulować recyrkulację, oświetlenie lub opcje czujnika w dowolnej kolejności. Wszystkie czynności należy jednak wykonać w ciągu dwóch minut.

Ustawianie trybu wentylacji lub recyrkulacji

Należy najpierw wyłączyć zasilanie i w ciągu 30 sekund od ponownego włączenia zasilania nacisnąć ikonę timera, a zmieni ona kolor na niebieski. Wyświetlacz LED pokaże aktualny tryb wentylacji lub recyrkulacji.

Tryb wentylacji . Ustawienie domyślne umożliwiające wyciąganie powietrza na zewnątrz.

Tryb recyrkulacji . Ustawienie recyrkulacji powietrza z zainstalowanymi filtrami węglowymi.

Aby zmienić tę opcję, za pomocą przycisku lub wybierz odpowiedni tryb, a następnie naciśnij przycisk ikony timera, aby zatwierdzić zmianę.



EN Use

PL Użytkowanie

FR Utilisation

RO Utilizare

Ustawianie trybu oświetlenia

W ciągu 30 sekund od włączenia zasilania sieciowego należy nacisnąć ikonę oświetlenia. Ikona oświetlenia zmieni kolor na niebieski. Wyświetlacz LED pokaże aktualny tryb oświetlenia.

Chłodne światło Ustawienie domyślne dla wszystkich światel.

Ciepłe światło Opcjonalne ustawienie dla wszystkich światel.

Aby zmienić te ustawienia, naciśnij lub , a następnie naciśnij ikonę oświetlenia, aby zatwierdzić zmianę.

Ustawianie czujnika ruchu

W ciągu 30 sekund od włączenia zasilania sieciowego naciśnij jednocześnie i przytrzymaj przez 2 sekundy ikony timera i oświetlenia, aby wyregulować czujnik ruchu. W razie potrzeby powtórz tę procedurę, aby zmienić ustawienie czujnika. Na wyświetlaczu LED pojawi się wybrany tryb.

Czujnik włączony wyświetlacz będzie migać przez 5 sekund – ustawienie domyślne.

Czujnik wyłączony wyświetlacz będzie świecił światłem ciągłym przez 5 sekund.



Uwaga: Aby później zmienić dowolne z tych ustawień, należy najpierw wyłączyć zasilanie z gniazda sieciowego. Odczekaj kilka sekund, ponownie włącz zasilanie i wyreguluj ustawienie zgodnie z wymaganiami.

02 Ogólne zastosowania

Wł./wył.

1. Dotknij ikony wł./wył. okapu, aby otworzyć szklany panel okapu. Wentylator włączy się przy prędkości 1 i lampka zapali się przy ostatnio używanym ustawieniu. Wszystkie ikony będą białe oprócz ikony oświetlenia, która będzie niebieska, jeśli światło było już włączone.

2. Ponownie naciśnij ikonę wł./wył., aby wyłączyć okap kuchenny; szyba zostanie zamknięta, a wentylator wyłączy się. Oświetlenie wyłączy się automatycznie po 5 minutach. Jeśli chcesz, aby oświetlenie było włączone przez dłuższy czas, włącz ją ręcznie na panelu sterowania.

Czujnik ruchu (jeśli jest włączony)

Okap kuchenny można włączyć, trzymając rękę przed czujnikiem ruchu. Uwaga: Nie można wyłączyć okapu za pomocą czujnika ruchu. Należy dotknąć ikony włączania/wyłączania okapu.

Włączanie/wyłączanie oświetlenia

1. Dotknij ikony oświetlenia, aby włączyć oświetlenie w dół.

2. Aby zmienić jasność oświetlenia w dół, dotknij i przytrzymaj ikonę oświetlenia, aż na wyświetlaczu pojawi się sekwencja jasności. Po uzyskaniu żądanej jasności zdejmij palec z ikony oświetlenia. Sekwencja przebiega stopniowo od L1 do L5 i z powrotem do L1. Wybrana jasność będzie migać przez kilka sekund i powróci do wyświetlania prędkości wentylatora

Włączanie/wyłączanie wentylatora i zmniejszanie jego prędkości

1. Jeśli silnik wentylatora jest ustawiony na prędkości 2, 3, 4, 5 lub P, naciśnięcie ikony zmniejszania prędkości wentylatora spowoduje zmniejszenie prędkości o jeden poziom. Naciśnięcie i przytrzymanie ikony zmniejszania prędkości wentylatora przez ponad dwie sekundy spowoduje spadek prędkości do 1 z dowolnego innego poziomu.

2. Jeśli silnik wentylatora jest ustawiony na prędkość 1, naciśnięcie ikony zmniejszania prędkości obrotowej wentylatora spowoduje wyłączenie silnika. Jednakże oświetlenie pozostanie włączone (jeśli jest włączone), a na wyświetlaczu pojawi się aktualny poziom jasności.

Funkcja podwyższenia mocy i zwiększenia prędkości

Jeśli prędkość obrotowa wentylatora jest ustawiona na 1, 2, 3, 4 lub 5, naciśnięcie ikony zwiększania prędkości wentylatora spowoduje stopniowe zwiększenie prędkości o jeden poziom. Naciśnięcie i przytrzymanie ikony zwiększania prędkości obrotowej wentylatora przez ponad dwie sekundy spowoduje zwiększenie prędkości do pełnej mocy z dowolnego poziomu. Na wyświetlaczu będzie migać litera „P”.



UWAGA: W celu oszczędzania energii praca przy pełnej mocy lub w trybie podwyższenia mocy (P) jest aktywna tylko przez pięć minut. Po tym czasie prędkość wentylatora automatycznie spada do poziomu 5.



Ustawianie timera ⌚

1. Po włączeniu silnika wentylatora i naciśnięciu ikony ⌚ timera ikona będzie migać na niebiesko, a na wyświetlaczu pojawi się aktualna prędkość wentylatora.
2. Wybrany poziom prędkości pozostanie w użyciu przez pięć minut, po czym spadnie do następnego w kolei. Nowa prędkość pozostanie aktywna przez dwie minuty, a potem zostanie zmniejszona. Proces ten będzie się powtarzał co dwie minuty, chyba że będzie już ustawiony poziom prędkości 1. Następnie wentylator się wyłączy. Jeśli włączono oświetlenie, ono także zostanie wyłączone.
3. Naciśnięcie ikony zmniejszenia prędkości lub zwiększenia prędkości wentylatora w trakcie działania bieżącego programu czasowego spowoduje ponowne rozpoczęcie pierwszego pięciominutowego cyklu odliczania.
4. Jeśli podczas bieżącego programu czasowego zostanie ponownie naciśnięty przycisk z ikoną ⌚ timera, cykl zostanie anulowany. Ikona ⌚ timera zmieni kolor na biały, a bieżąca prędkość wentylatora pozostanie włączona na czas nieokreślony.
5. Maksymalny czas trwania programu wynosi 15 minut: 5 minut w przypadku P, a następnie 2 minuty w przypadku prędkości od 5 w dół do 1.

PL Zdalne sterowanie okapem kuchennym GoodHome



WAŻNE: Ta część ma zastosowanie tylko w przypadku zakupu płyty indukcyjnej GoodHome.



Proces podłączania okapu do płyty grzewczej przebiega w trzech etapach:

- A) Ustaw płytę grzewczą tak, aby emitowała sygnał o częstotliwości radiowej.
- B) Skonfiguruj okap, aby odebrać ten sygnał.
- C) Nawiąż połączenie między dwoma urządzeniami i zakończ proces parowania.

ETAP A

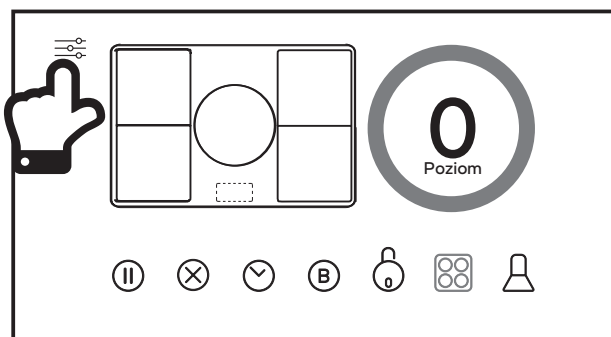
1. Przed kontynuowaniem należy włączyć płytę indukcyjną i wyświetlony winien być ekran główny.



2. Dotknij przycisku menu  głównego na ekranie głównym, aby przejść do menu ustawień. Dotknij ikony  łączenia, aby rozpocząć sekwencję parowania i przestać sygnał częstotliwości radiowej z płyty grzewczej. Nie dotykaj jeszcze przycisku okapu na płycie grzewczej!

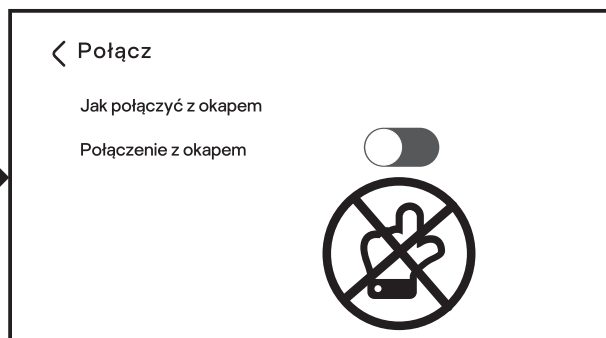

WAŻNE: Aby kontynuować łączenie, należy wyłączyć okap za pomocą wyłącznika zasilania sieciowego. Ponownie włącz okap i w ciągu dwóch minut wykonaj etapy B i C. Jeśli połączenie nie zostanie nawiązane, wyłącz ponownie okap, odczekaj minutę i spróbuj ponownie.



ETAP B

1. Po pierwszym włączeniu okapu panel sterowania zamiga na biało w trybie ustawień.
2. Na panelu sterowania okapu należy dotknąć i przytrzymać przez dwie sekundy jednocześnie ikonę zwiększania prędkości wentylatora i ikonę zmniejszania prędkości obrotowej wentylatora. Obie ikony zmienią kolor na niebieski, a na wyświetlaczu pojawi się symbol „A” automatycznej pracy wentylatora. Okap jest skonfigurowany tak, aby odbierał sygnał.

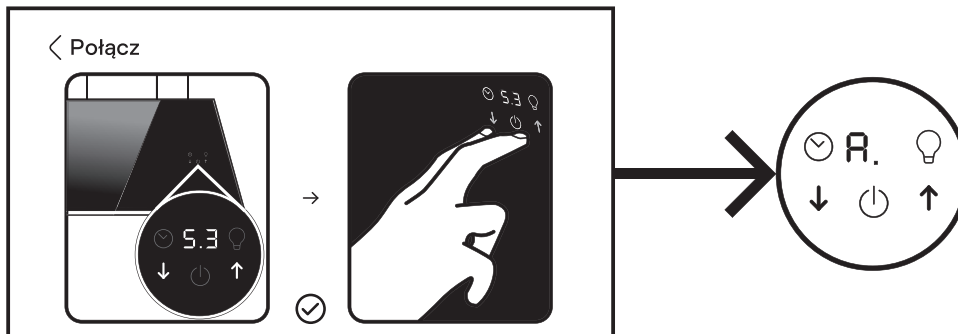

ETAP C

1. Teraz dotknij przycisku okapu na płycie grzewczej,  a symbol zmieni kolor na niebieski.
2. Na krótko pojawi się komunikat informujący o tym, że płyta jest powiązana z okapem i proces parowania został zakończony. Na okapie znajdują się również podwójne symbole „A”, które wskazują, że parowanie zostało zakończone.

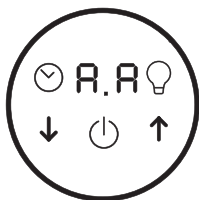
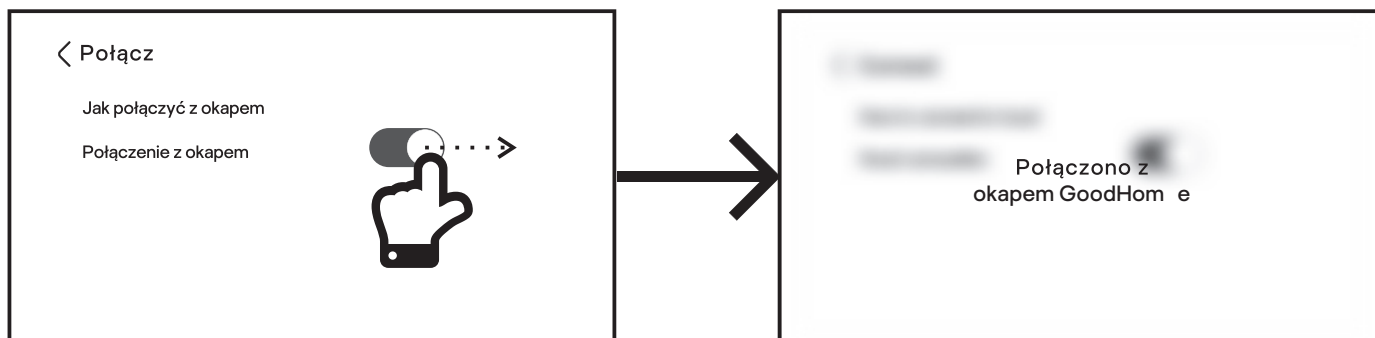

WAŻNE: Po połączeniu i powiązaniu płyty grzewczej z okapem można wybrać jeden z trzech sposobów korzystania z urządzeń GoodHome: niezależnego sterowania, sterowania półautomatycznego i automatycznego.

1. Niezależne sterowanie – przycisk okapu na płycie grzewczej jest WYŁĄCZONY i można ręcznie sterować wentylatorem okapu oraz siłą wyciągu niezależnie od ustawień płyty grzewczej.

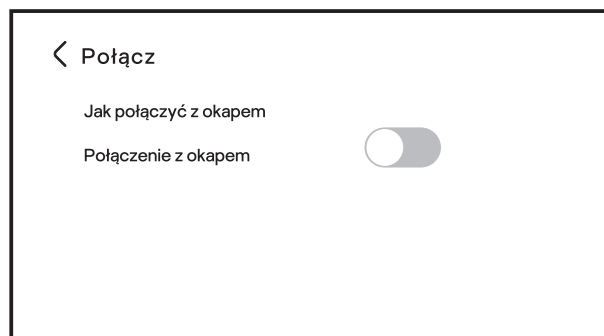



2. Sterowanie półautomatyczne – przycisk okapu na płycie jest **WŁĄCZONY** i można sterować wentylatorem okapu i wyciągiem za pomocą głównego przycisku sterowania 360 na panelu sterowania płyty grzewczej.

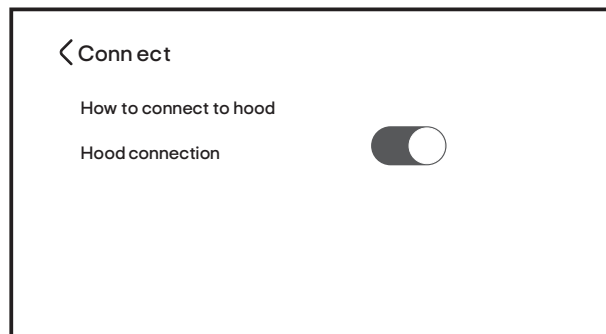

3. Automatyczne sterowanie – przycisk okapu na płycie jest **WŁĄCZONY**, a płyta grzewcza kontroluje wentylator i wyciąg w zależności od poziomu mocy używanej na płycie.

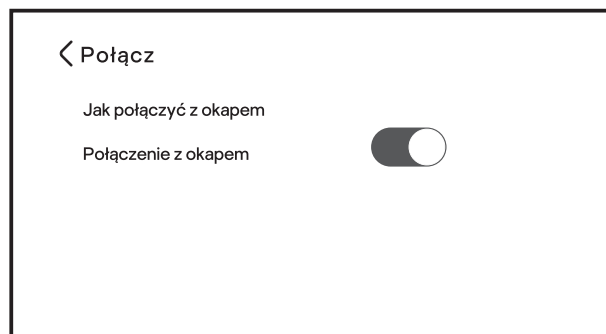

UWAGA: Nie ma konieczności ponownego parowania urządzeń po wyłączeniu połączenia Hood na płycie. Łącze zostanie zapisane w pamięci i uaktywnione po ponownym włączeniu okapu.

UWAGA: Jeśli dotkniesz klawisza panelu sterowania okapem kuchennym przed zakończeniem połączenia, na ekranie pojawi się następujący komunikat:

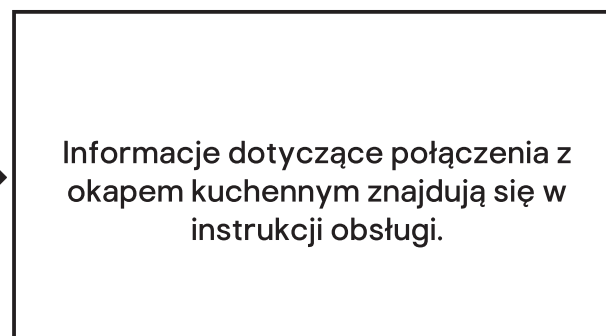
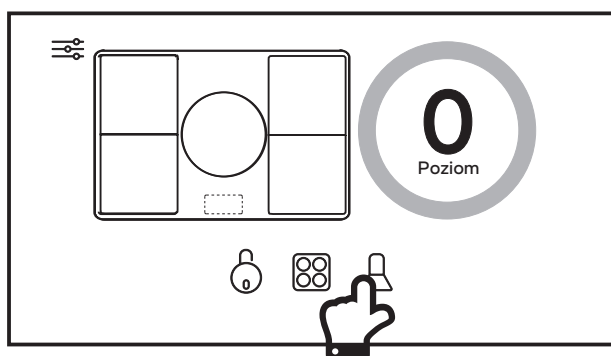

01 Sterowanie okapem kuchennym z poziomu płyty grzewczej

Upewnij się, że łączenie płyty grzewczej i okapu zostało ukończony, a przycisk połączenia okapu jest **WŁĄCZONY**!

1. Na ekranie głównym płyty dotknij ikony okapu kuchennego, aby uzyskać dostęp do panelu sterowania okapem, a ikona zmieni kolor na niebieski.

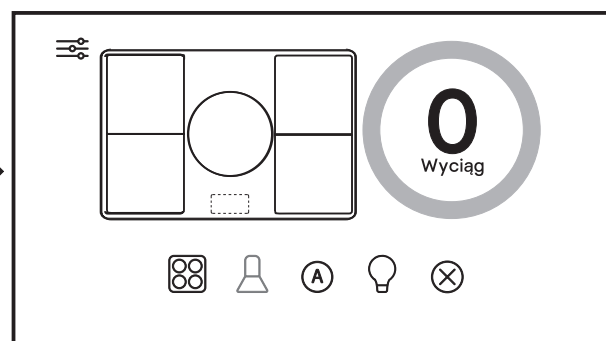
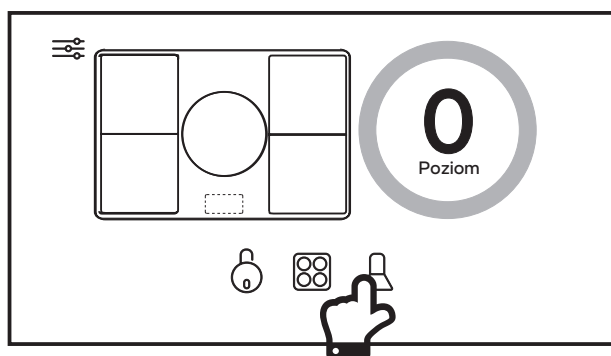

2. Aby sterować szybkością wyciągu okapu, należy ręcznie obrócić lub dotknąć główny przycisk sterujący 360° od 0 do 5 oraz przycisk B w przypadku zwiększenia mocy. Ikona wł./wył. okapu będzie migać naprzemiennie na niebiesko i biało. Jest to sterowanie półautomatyczne.

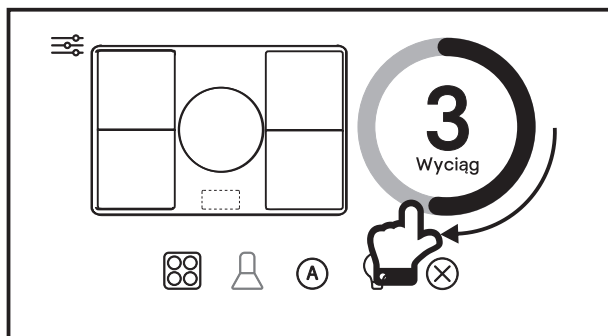

3. Aby automatycznie sterować siłą wyciągu okapu, dotknij ikony automatycznego sterowania wyciągiem **A** na płycie grzewczej. Ikona zmieni kolor na zielony, a płyta automatycznie dostosuje moc wyciągu zgodnie z mocą wyjściową płyty grzewczej. Szczegółowe informacje znajdują się w poniższej tabeli. Jest to sterowanie automatyczne.

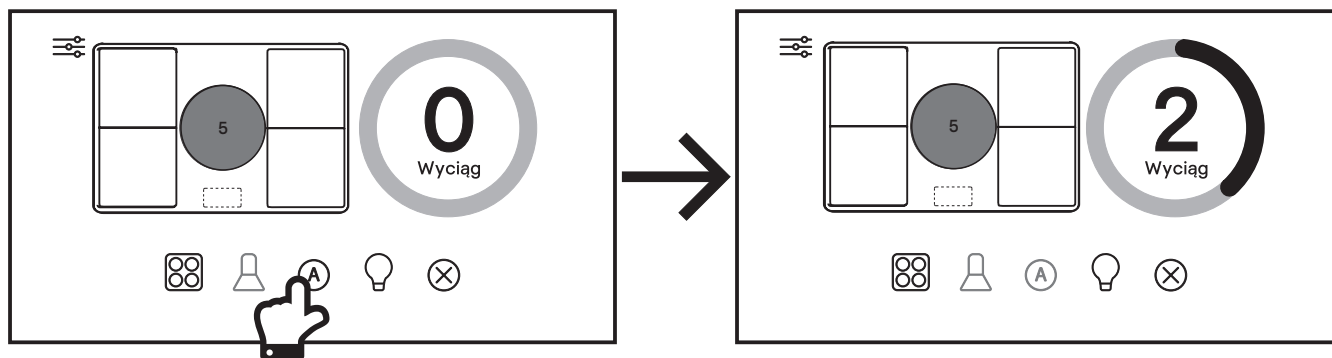

WAŻNE: Moc wyciągu okapu będzie się wahać w zależności od całkowitej mocy wyjściowej wybranej na płycie, jak pokazano w tabeli poniżej.

Poziom prędkości wentylatora okapu	Łączna moc wyjściowa płyty
Prędkość 2	Ta prędkość zostanie wybrana, gdy łączna moc wyjściowa wszystkich stref wynosi 8 lub mniej. Na przykład strefa A jest ustawiona na 3, a strefa B na 4.
Prędkość 4	Ta prędkość zostanie wybrana, gdy łączna moc wyjściowa wszystkich stref mieści się w zakresie od 9 do 24. Na przykład: Strefa A jest ustawiona na 3, strefa B na 4, a strefa D na 6.
Prędkość 5	Ta prędkość zostanie wybrana, gdy łączna moc wyjściowa wszystkich stref mieści się w zakresie od 25 do 32. Na przykład strefa A jest ustawiona na 9, strefa B na 8, strefa D na 8, a strefa E na 4.
Prędkość P – zwiększenie mocy	Ta prędkość zostanie wybrana, gdy łączna moc wyjściowa wszystkich stref przekroczy 32. Na przykład strefa A jest ustawiona na 8, strefa B na 7, strefa D na 9, strefa E na 6 a strefa F na 6.

Uwaga: W przypadku korzystania z tej funkcji nie są dostępne prędkości okapu 1 i 3.



WAŻNE: NIE MOŻNA zmienić bieżącego stanu okapu na panelu sterowania w trybie sterowania automatycznego. W przypadku próby wyłączenia okapu płyta grzewcza samoczynnie włączy się!

Jeśli chcesz ponownie ręcznie sterować okapem i powrócić do trybu niezależnego sterowania, wyłącz ikonę automatycznego sterowania wyciągiem i wyłącz przycisk połączenia okapu na płycie grzewczej.

W obu trybach automatycznych i jeśli żadna strefa gotowania płyty nie jest aktywna, okap automatycznie przechodzi w tryb timera po jednej minucie bezczynności i kolejno zmniejsza poziom mocy, aby po krótkim czasie wyłączyć okap. Więcej informacji znajduje się w części instrukcji obsługi okapu dotyczącej timera.

UWAGA: Gdy płyta jest nadal włączona, ikona wł./wył. na okapie będzie migać, ale jeśli płyta zostanie wyłączona w trybie timera, migać będzie ikona timera na okapie, a poziomy mocy będą zmniejszane stopniowo, aby wyłączyć okap.



02 Zmiana koloru i jasności oświetlenia w okapie kuchennym z poziomu płyty

1. Wybierz panel sterowania okapem kuchennym z menu głównego. Dotknij ikony sterowania oświetleniem, aby wybrać funkcję regulacji jasności.

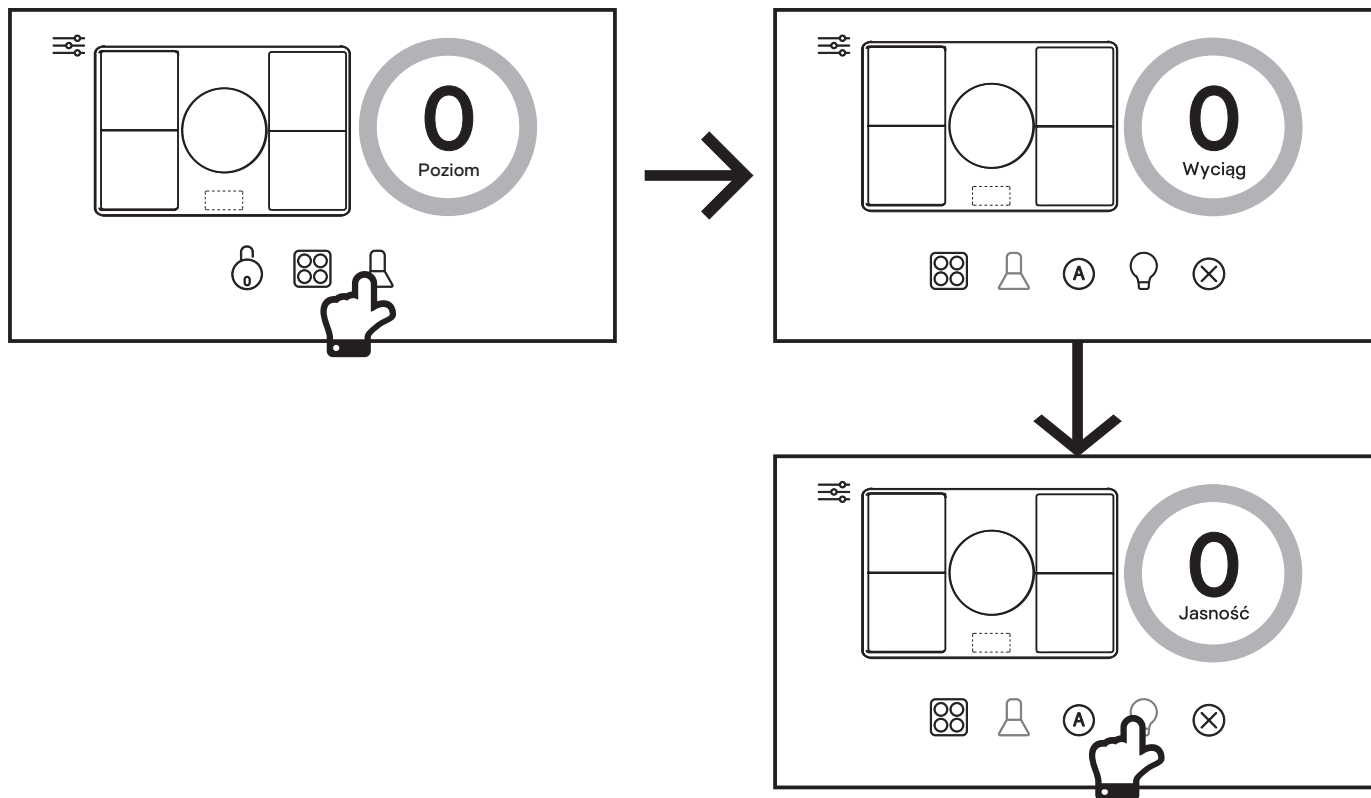

2. Ustaw poziom jasności, obracając główny przycisk sterujący 360° w zakresie od 0 do 5.

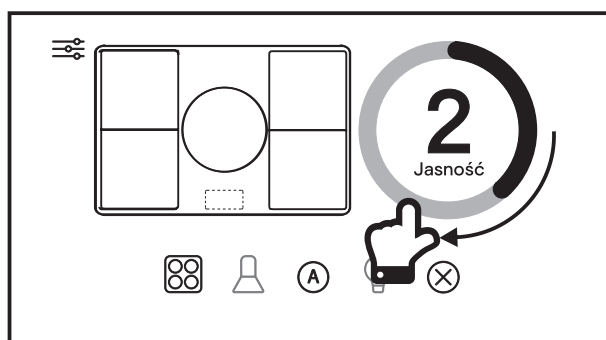

3. Temperaturę barwy oświetlenia możesz również regulować dotykając ikony  sterowania oświetleniem w następującej kolejności:

(a) Niebieski – chłodna biel (ustawienie domyślne).

(b) Pomarańczowy – ciepła biel.

Uwaga: Oświetlenie można wyłączyć, dotykając ikony zatrzymania .

Podczas przesyłania tego sygnału do okapu występuje niewielkie opóźnienie.

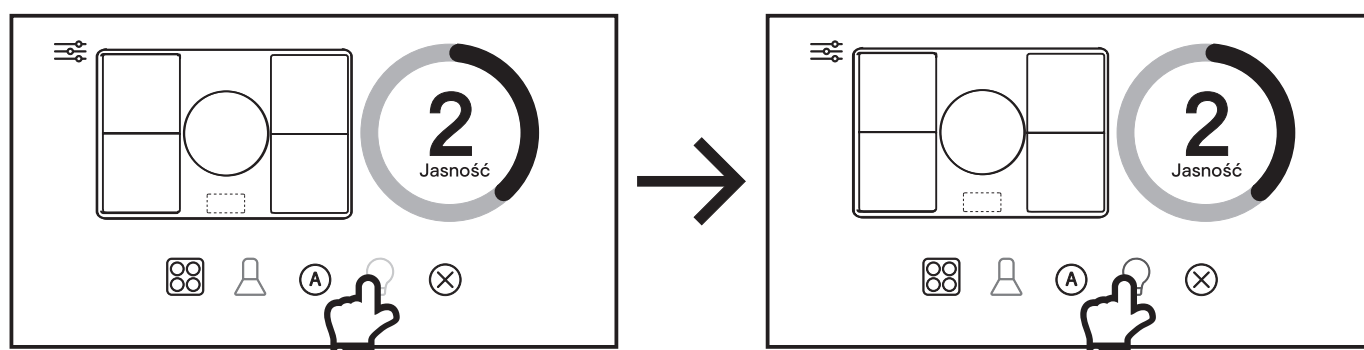



RO Înainte de a începe



AVERTISMENT: Citiți instrucțiunile înainte de utilizarea aparatului.

Porniți aparatul de la unitatea de conectare cu comutator de siguranță. Aparatul este gata de utilizare.

RO Funcție și setări

01 Panou de control

Pentru a obține cele mai bune rezultate de la hota de bucătărie, se recomandă să o lăsați pornită o perioadă scurtă după ce ați terminat gătitul.

	Temporizator	
	Funcția de amplificare și mărire a turației ventilatorului	
	Pornire/oprire hotă	
	Afișaj cu LED	
	Reducerea vitezei ventilatorului	
	Pornire/oprire lumină	
	Senzor de mișcare	

Configurare pentru prima utilizare

În momentul în care ați pornit aparatul de la unitatea de conectare cu comutator de siguranță, toate pictogramele vor începe să lumineze intermitent alb. Acum hota este în modul de configurare.

Dacă nu doriți să configurați hota în acest moment, aceasta poate fi oprită apăsând pictograma de pornire/oprire a hotei sau se va opri automat după 30 de secunde.



IMPORTANT: În momentul în care ați intrat în modul de configurare, puteți regla opțiunile cu privire la recirculare, iluminat sau senzor în ordinea dorită. Cu toate acestea, toate operațiile trebuie să fie realizate într-un interval de două minute.

Configurarea modului cu tubulatură sau cu recirculare

Mai întâi opriți alimentarea și, în 30 de secunde de la repornirea sursei de alimentare, apăsați pictograma Temporizator, care va deveni albastră. Afișajul cu LED va indica modul curent cu tubulatură sau de recirculare.

Modul cu tubulatură . Setarea implicită este extragerea aerului la exterior.

Modul recirculare . Setarea de recirculare a aerului cu filtrele de carbon este instalată.

Ca să schimbați această opțiune, apăsați sau pentru a selecta modul corect, apoi apăsați pictograma Temporizator pentru a accepta modificarea.



EN Use

PL Użytkowanie

FR Utilisation



RO Utilizare

Configurarea modului de iluminare



În 30 de secunde de la pornirea sursei de alimentare, apăsați pictograma Lumină , care va deveni albastră. Afișajul cu LED va indica modul curent de iluminare.

Lumină rece . Setare implicită pentru toate luminile.

Lumină caldă . Setare opțională pentru toate luminile.

Pentru a schimba aceste setări, apăsați  sau  și apăsați pictograma Lumină pentru a confirma modificarea.

Configurarea senzorului de mișcare

În 30 de secunde de la pornirea sursei de alimentare, apăsați pictogramele   Temporizator și Lumină simultan timp de 2 secunde, pentru a regla senzorul de mișcare. Repetați acest proces pentru a modifica setarea senzorului dacă este necesar.

Afișajul cu LED va indica modul selectat.

Senzor activat . Afișajul va lumina intermitent timp de 5 secunde - setare implicită.

Senzor dezactivat . Afișajul va rămâne neschimbat timp de 5 secunde.



Notă: Pentru a modifica oricare dintre aceste setări ulterior, mai întâi trebuie să opriți alimentarea electrică de la rețea. Așteptați câteva secunde, porniți din nou alimentarea electrică și reglați după cum este necesar.

02 Uz general

Pornit/Oprit

1. Atingeți pictograma pornit/oprit de pe hotă și panoul din sticlă al hotei de bucătărie se va deschide. Ventilatorul va porni la viteza 1 și lumina se va aprinde la ultima setare folosită. Toate pictogramele  vor fi albe, în afara pictogramei Lumină, care va fi albastră dacă lumina era deja pornită.

2. Apăsați din nou pictograma Pornire/oprire pentru a opri hota; panoul din sticlă se va închide, iar ventilatorul se va opri. Lumina se va stinge de asemenea automat după 5 minute. Dacă doriți să lăsați lumina aprinsă pentru o perioadă mai lungă de timp, aprindeți-o manual de la panoul de control.

Senzorul de mișcare  (dacă este activat)

Puteți porni hota de bucătărie trecând mâna prin fața senzorului de mișcare. Rețineți că nu puteți opri hota de bucătărie folosind senzorul de mișcare, ci trebuie să atingeți pictograma  Pornit/oprit.

Pornire/oprire lumină

1. Atingeți pictograma Lumină pentru a aprinde lumina.

2. Pentru a modifica luminozitatea luminii orientate în jos, atingeți și mențineți apăsată pictograma  Lumină, până când pe afișaj apare secvența de luminozitate. Luați degetul de pe pictograma Lumină în momentul în care este obținută luminozitatea dorită. Secvența se derulează treptat de la L1 la L5 și înapoi la L1. Luminozitatea selectată va fi afișată intermitent timp de câteva secunde și va reveni la afișarea vitezei ventilatorului

Pornire/oprire ventilator și reducere turație

1. Dacă motorul ventilatorului este reglat la vitezele 2, 3, 4, 5 sau P, prin apăsarea pictogramei de Reducere a vitezei ventilatorului se va reduce viteza cu câte un nivel. Dacă apăsați pictograma de Reducere a vitezei ventilatorului mai mult de două secunde, viteza va fi redusă la viteza 1 de la orice nivel.

2. Dacă motorul ventilatorului este la viteza 1, prin apăsarea pictogramei de Reducere a vitezei ventilatorului, motorul va fi oprit. Cu toate acestea, lumina orientată în jos va rămâne pornită (dacă este activată) și pe afișaj va apărea nivelul curent de luminozitate.

Funcția de amplificare și mărirea turației

Dacă motorul ventilatorului este reglat la vitezele 1, 2, 3, 4 sau 5, prin apăsarea pictogramei de Mărire a vitezei ventilatorului se va mări viteza cu câte un nivel. Dacă apăsați pictograma de Mărire a vitezei ventilatorului mai mult de două secunde, viteza va crește la maximum de la orice nivel și afișajul va lumina intermitent „P”.



NOTĂ: Funcțiile Putere maximă sau Amplificare (P) funcționează numai timp de maximum cinci minute, pentru a economisi energia, iar turația ventilatorului va scădea automat la nivelul 5 după acest interval.

Setarea temporizatorului

1. Atunci când motorul ventilatorului este pornit și pictograma  Temporizator este apăsată, pictograma va lumina intermitent albastru, iar pe afișaj va apărea viteza curentă a ventilatorului.

2. Nivelul de turație ales va fi menținut timp de cinci minute înainte de a scădea la următoarea turație inferioară. Această turație va fi menținută timp de două minute înainte de a scădea din nou. Aceasta se va repeta la fiecare două minute, cu excepția



EN Use

PL Użytkowanie

FR Utilisation

RO Utilizare

59

cazului în care turația este deja la nivelul 1, iar ventilatorul se va opri. Dacă lumina este deja aprinsă, și aceasta se va stinge.

3. Apăsarea pictogramei Reducere viteză ventilator sau Mărire viteză ventilator în timpul unui program curent cu temporizator va reporni procesul de cronometrare pentru primul ciclu de cinci minute.

4. Dacă pictograma ⏸ Temporizator este apăsată din nou în timpul unui program curent cu temporizator, ciclul va fi anulat. Pictograma ⏸ Temporizator va redeveni albă, iar viteza curentă a ventilatorului va rămâne setată pentru o perioadă nedefinită

5. Ciclul maxim de programare a temporizatorului este de 15 minute: 5 minute la P și apoi câte 2 minute de la turația 5 până la turația 1.

RO Controlarea de la distanță a unei hote de bucătărie GoodHome



IMPORTANT: Această secțiune se aplică numai dacă ați cumpărat o plită cu inducție GoodHome.

Procesul de conectare a hotei la plită constă în trei etape:

A) Configurați plita pentru a transmite un semnal de frecvență radio.

B) Configurați hota pentru a recepționa acest semnal.

C) Blocați conectivitatea dintre cele două aparate și finalizați procesul de asociere.

ETAPA A

1. Plita cu inducție trebuie să fie pornită și trebuie să afișeze ecranul principal înainte de a continua.

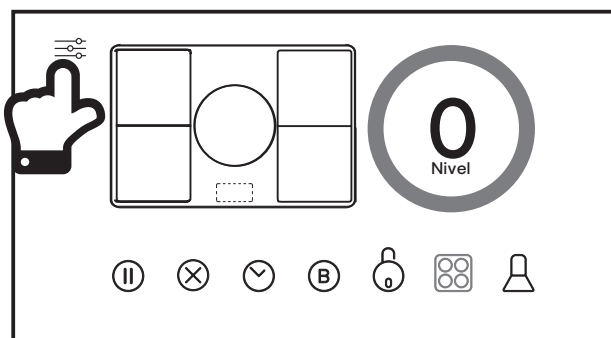

2. Atingeți tasta Meniu ☰ principal de pe ecranul principal pentru a merge la meniul de Setări. Atingeți pictograma 📶 Conectare pentru a iniția secvența de asociere și a transmite un semnal de frecvență radio de la plită. Nu atingeți încă butonul de conectare a Hotei de pe plită!

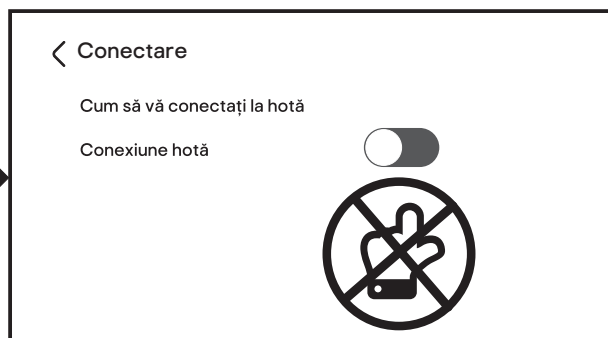
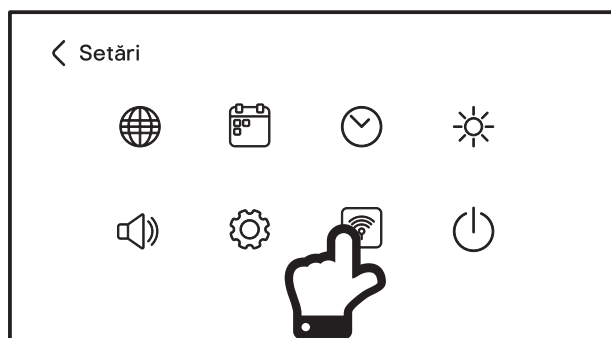

IMPORTANT: Pentru a începe operațiunea de conectare, hota trebuie să fie oprită de la întrerupătorul sursei de alimentare. Porniți din nou hota și finalizați Etapele B și C în două minute. În cazul în care conexiunea nu este realizată cu succes, opriți din nou hota, așteptați un minut și încercați din nou.



ETAPA B

1. Atunci când hota este pornită pentru prima dată, panoul de control va lumina intermitent alb în modul Setări.
2. Atingeți simultan pictograma de Mărire a vitezei ventilatorului și pictograma de Reducere a vitezei ventilatorului de pe panoul de control al hotei timp de două secunde și ambele pictograme vor deveni albastre, iar simbolul Automat „A” va apărea pe afișaj. Hota este configurată pentru a primi semnalul.

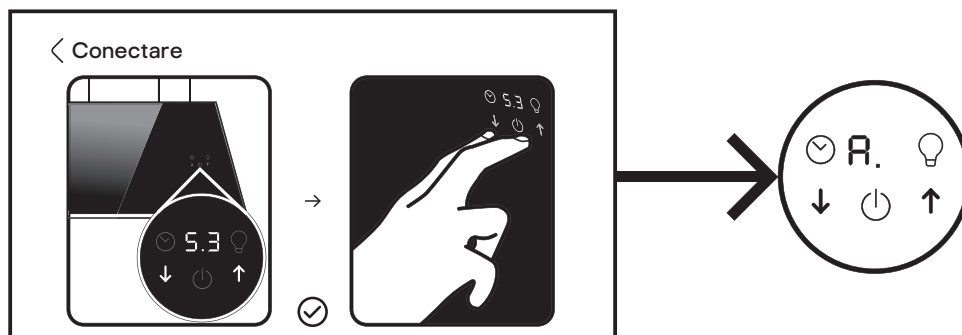

ETAPA C

1. Acum atingeți butonul  de conectare a Hotei de pe plită și acesta va deveni albastru.
2. Plita va afișa pentru scurt timp un mesaj de conectare, pentru a indica faptul că plita este acum conectată la hotă și că procesul de asociere a fost finalizat. De asemenea, hota va afișa simbolurile duble „A” pe panoul său de control, pentru a arăta că s-a realizat asocierea.

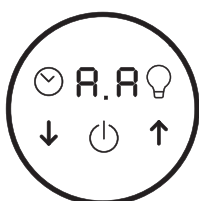
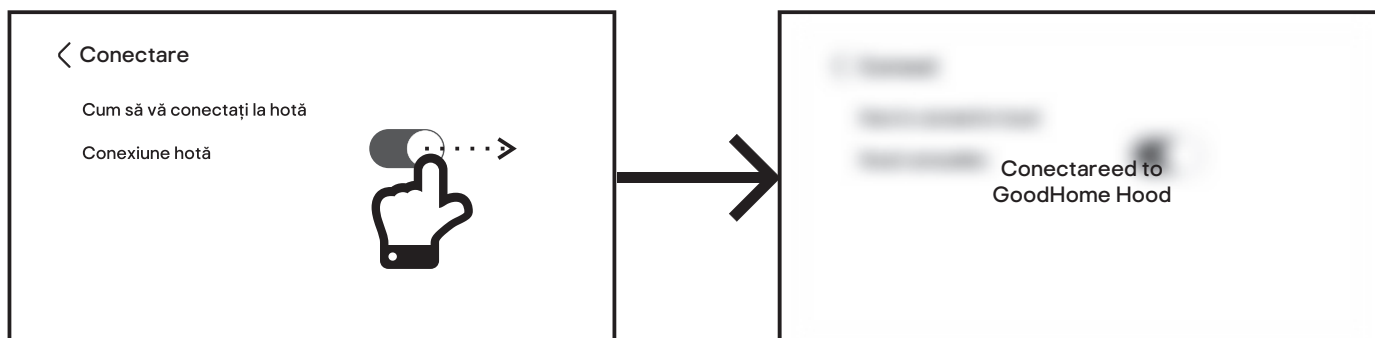

IMPORTANT: După ce plita și hota sunt asociate și blocate, puteți alege să folosiți aparatele GoodHome în trei moduri: Control independent, Control semiautomat și Control automat.

1. Control independent - Butonul de conectare a Hotei de pe plită este oprit și puteți opera manual ventilatorul hotei și viteza de evacuare, după cum este necesar, independent de setările plitei.

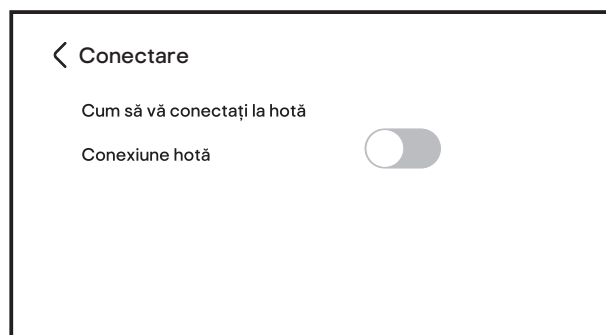



2. Control semiautomat - Butonul de conectare a Hotei de pe plită este pornit și puteți gestiona manual ventilatorul hotei și viteza de evacuare cu ajutorul butonului Principal 360 de pe panoul de control al plitei.

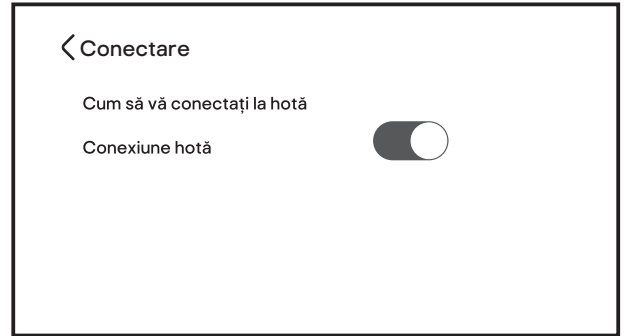

3. Control automat - Butonul de conectare a Hotei de pe plită este pornit și plita va controla ventilatorul hotei și viteza de evacuare pe baza nivelurilor de putere folosite la plită.

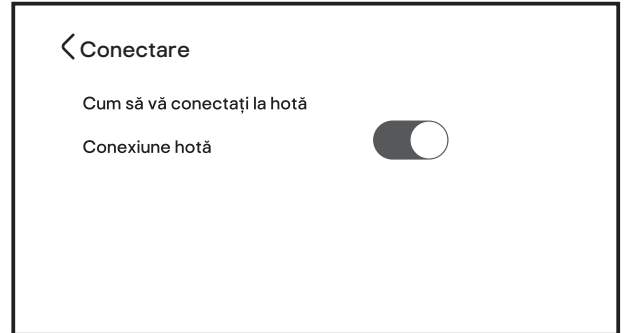

NOTĂ: Nu este necesar să desfășurați din nou procesul de asociere, dacă opriți conexiunea hotei de la plită. Conexiunea este stocată în memorie și va fi reactivată după ce reporniți conexiunea Hotei.

NOTĂ: Dacă atingeți tasta de pe panoul de control al hotei de bucătărie înainte de finalizarea conexiunii, vezi vedea acest mesaj pe ecran:

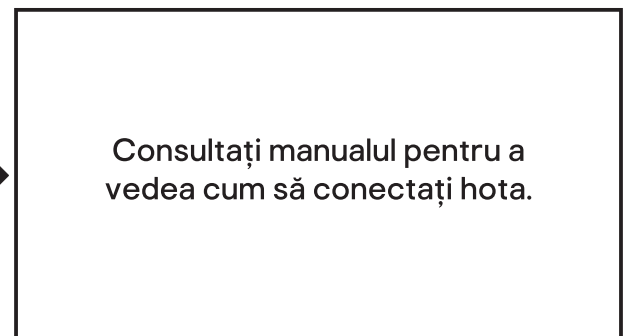
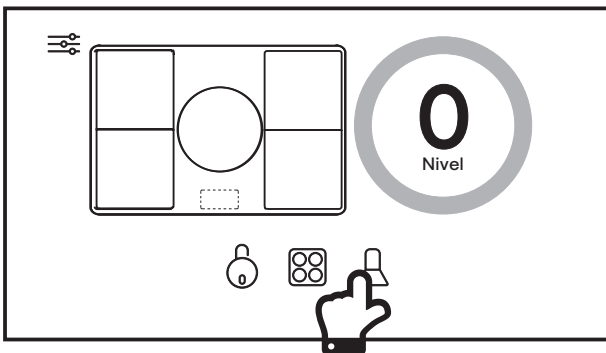

01 Controlarea hotei de bucătărie de la plită

Asigurați-vă că s-a realizat conexiunea dintre plită și hotă și că butonul de conexiune a hotei este pornit!

1. De pe ecranul principal al plitei, atingeți pictograma  Hotă de bucătărie pentru a accesa panoul de control al hotei de bucătărie; pictograma va deveni albastră.

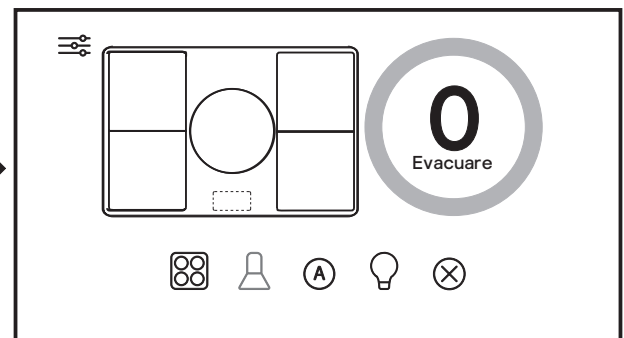
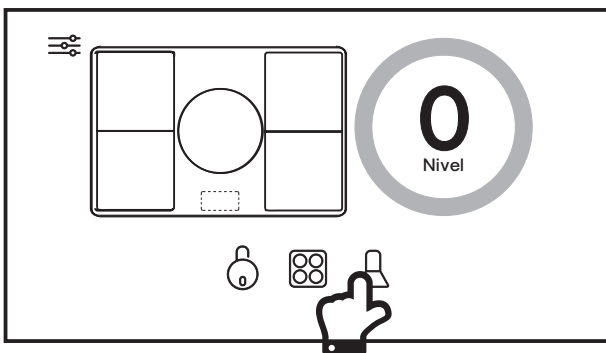



2. Pentru a controla manual viteza de evacuare a hotei, rotiți sau atingeți tasta de control principal 360° de la 0-5 și B pentru amplificare. Pictograma Pornire/Oprire Hotă de pe hotă se va lumina intermitent alternativ albastru și alb. Acesta este controlul semiautomat.

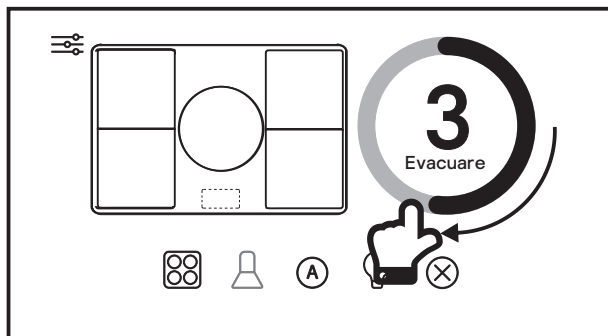

3. Pentru a controla automat viteza de evacuare a hotei, atingeți pictograma Control automat (A) de pe plită. Pictograma va deveni verde, iar plita va regla automat viteza de evacuare a hotei în conformitate cu puterea de ieșire a plitei. Consultați tabelul de mai jos pentru detalii. Aceasta este controlul automat.

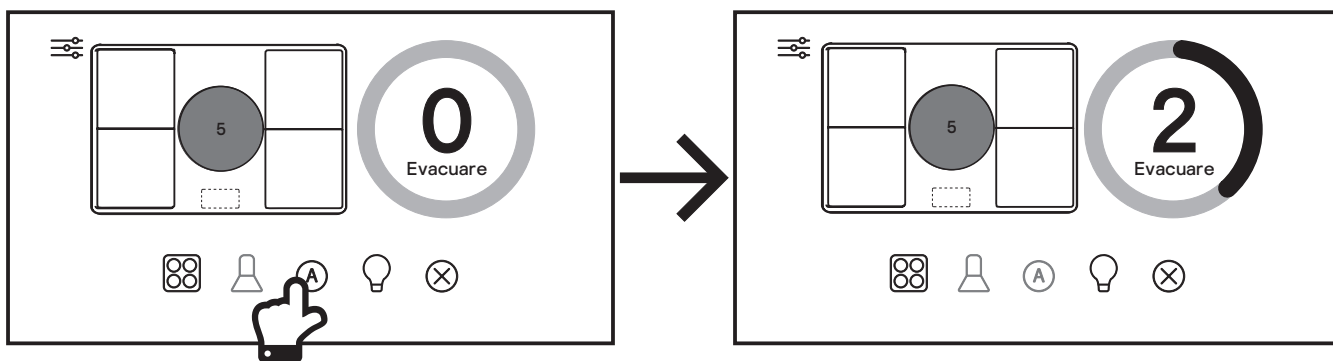

IMPORTANT: Viteza de evacuare a hotei va varia în funcție de puterea generată totală selectată pentru plită, așa cum este indicat în tabel de mai jos.

Nivelul de turație al hotei	Puterea generată combinată a plitei
Turația 2	Această turație va fi selectată când puterea combinată a tuturor zonelor este de maximum 8. De exemplu, Zona A este la 3 și Zona B este la 4.
Turația 4	Această turație va fi selectată când puterea combinată a tuturor zonelor este între 9 și 24. De exemplu, Zona A este la 3, Zona B este la 4 și Zona D este la 6.
Turația 5	Această turație va fi selectată când puterea combinată a tuturor zonelor este între 25 și 32. De exemplu, Zona A este la 9, Zona B este la 8, Zona D este la 8 și Zona E este la 4.
Turația P - Amplificare	Această turație va fi selectată când puterea combinată a tuturor zonelor este mai mare de 32. De exemplu, Zona A este la 8, Zona B este la 7, Zona D este la 9, Zona E este la 6 și Zona F este la 6.

Notă: Turația 1 și Turația 3 ale hotei nu sunt disponibile când se utilizează această funcție.

IMPORTANT: Rețineți că NU PUTEȚI trece peste starea curentă a hotei de la panoul de control când aceasta funcționează în modul Control automat. Dacă încercați să opriți hota, plita o va reporni!

Dacă doriți să controlați din nou în mod manual hota și să reveniți la Control independent, dezactivați pictograma Control automat evacuare și comutați butonul Conexiune hotă de pe plită la poziția oprit.

În ambele moduri automate, dacă niciuna dintre zonele de gătit ale plitei nu este activă, hota va intra automat în modul Temporizator după un minut de inactivitate și va reduce treptat nivelul de putere, până când se va opri după o scurtă perioadă. Pentru mai multe detalii, consultați secțiunea Temporizator din manualul hotei.

NOTĂ: În timp ce plita este încă pornită, pictograma Pornire/Oprire de pe hotă va lumina intermitent, în schimb dacă plita este oprită în Modul Temporizator, pictograma Temporizator de pe hotă va lumina intermitent și va reduce treptat nivelul de putere până când se va opri.



02 Modificarea culorii lămpii și a luminozității hotei de bucătărie de la plită

1. Selectați Panoul de control al hotei de bucătărie din Meniul principal. Atingeți pictograma Control lumină pentru a selecta funcția de control luminozitate.

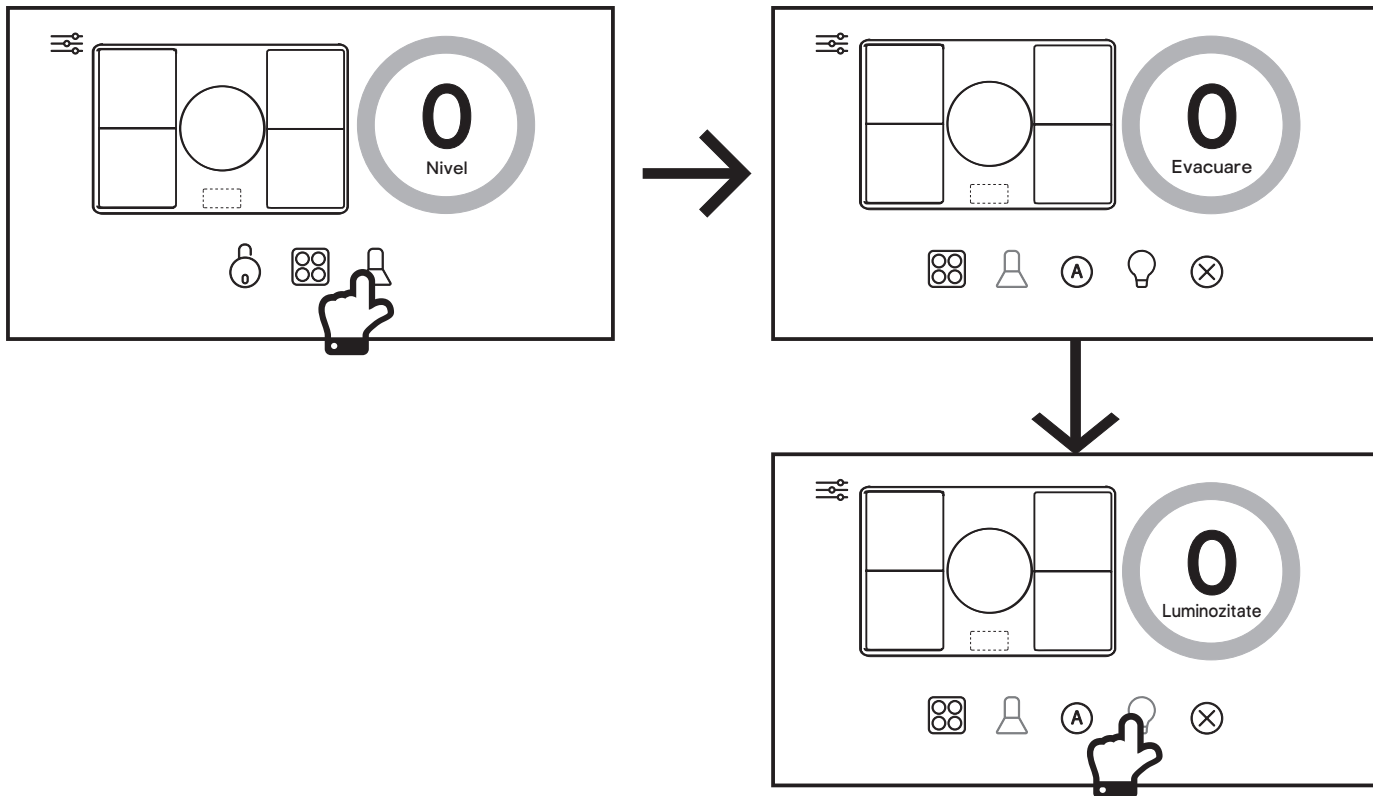

2. Reglați nivelul de luminozitate rotind tasta de control principal 360° între 0-5.

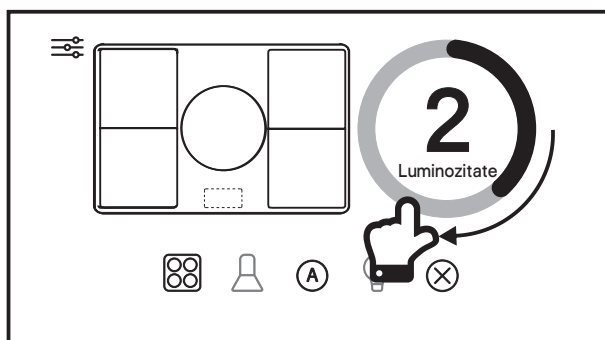

3. Puteți să reglați temperatura de culoare a lămpii și prin atingerea pictogramei Control lumină în următoarea ordine:

(a) Albastru - lumină albă rece (implicit).

(b) Portocaliu - lumină albă caldă.

Notă: Puteți opri lampa apăsând pictograma Stop .

Va exista o ușoară întârziere la transmiterea acestui semnal către hotă.

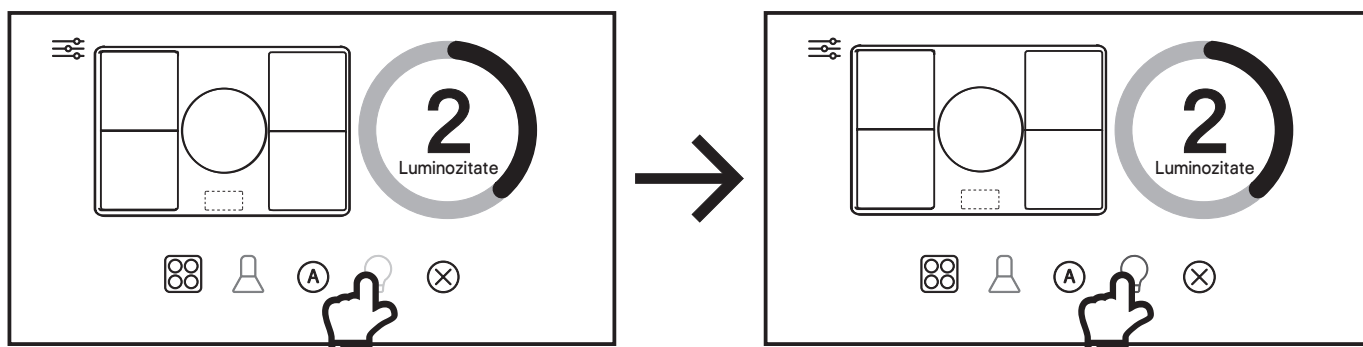



EN Care and Maintenance

01 Carbon filter replacement



Replace carbon filters every three months.

To change the carbon filters:

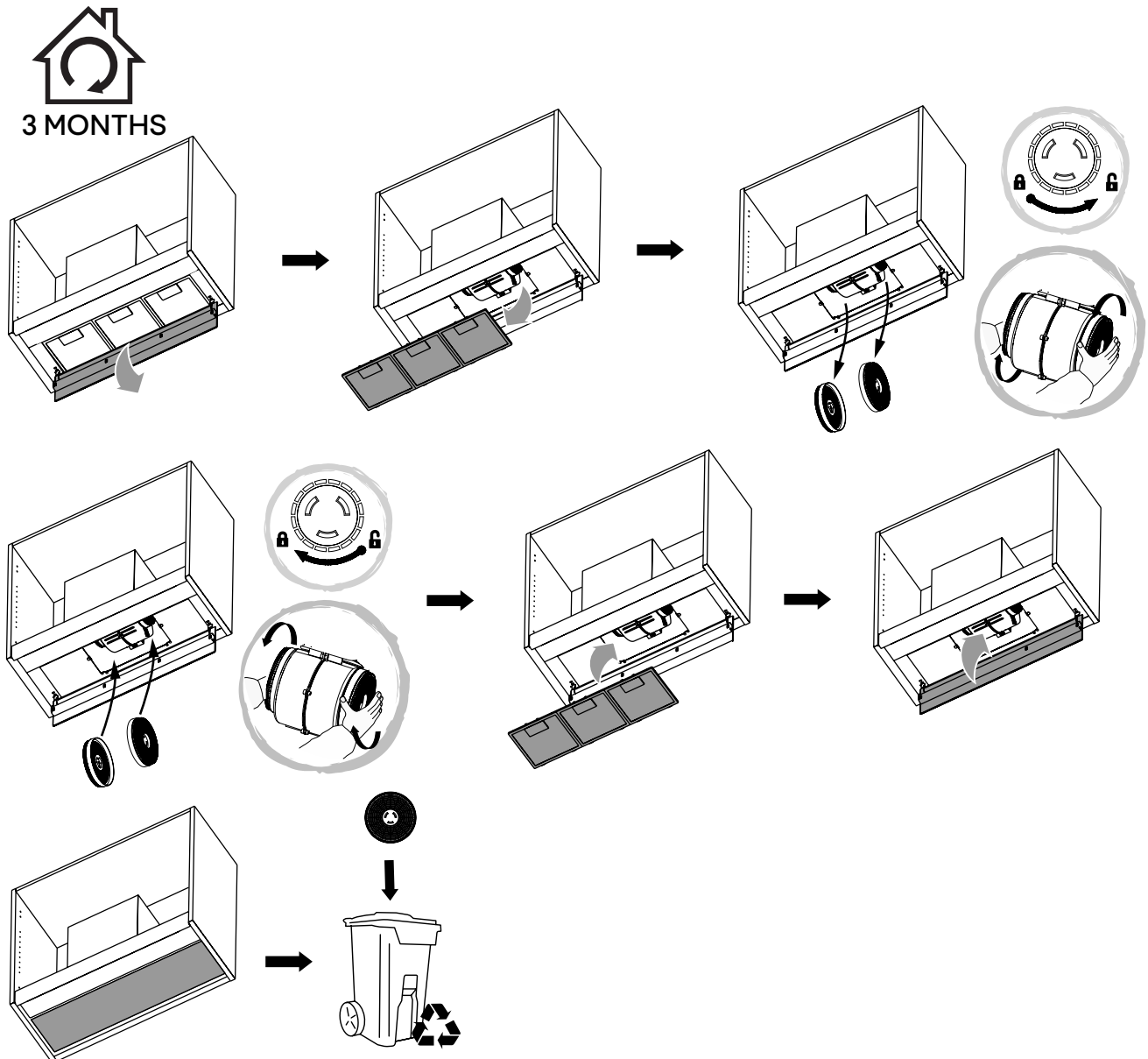
1. Pull the rear glass panel down to open it.
2. Remove the aluminium grease filters.
3. Change the carbon filters.
4. Replace the grease filters.
5. Close the rear glass panel.



2x Carbon filter, model: CARBFILT 50 available via the Customer Helpline - see end of Care & Maintenance section for details.

If the motor is off, and after the fan has been in operation for approximately 150 hours. The display will show  and the Timer will flash blue to advise you to replace the carbon filters. After replacing the filters, reset the alert by pressing the Timer icon .



WARNING: Always switch off the electrical supply before carrying out maintenance work on the hood. In the event of a fault, contact Customer Services.





02 Aluminium grease filter cleaning

Aluminium filters: To avoid fires, clean thoroughly once a month. Remove both grease filters as shown and soak in hot water and detergent for an hour. If using a dishwasher, position the filters vertically to improve the cleaning process.

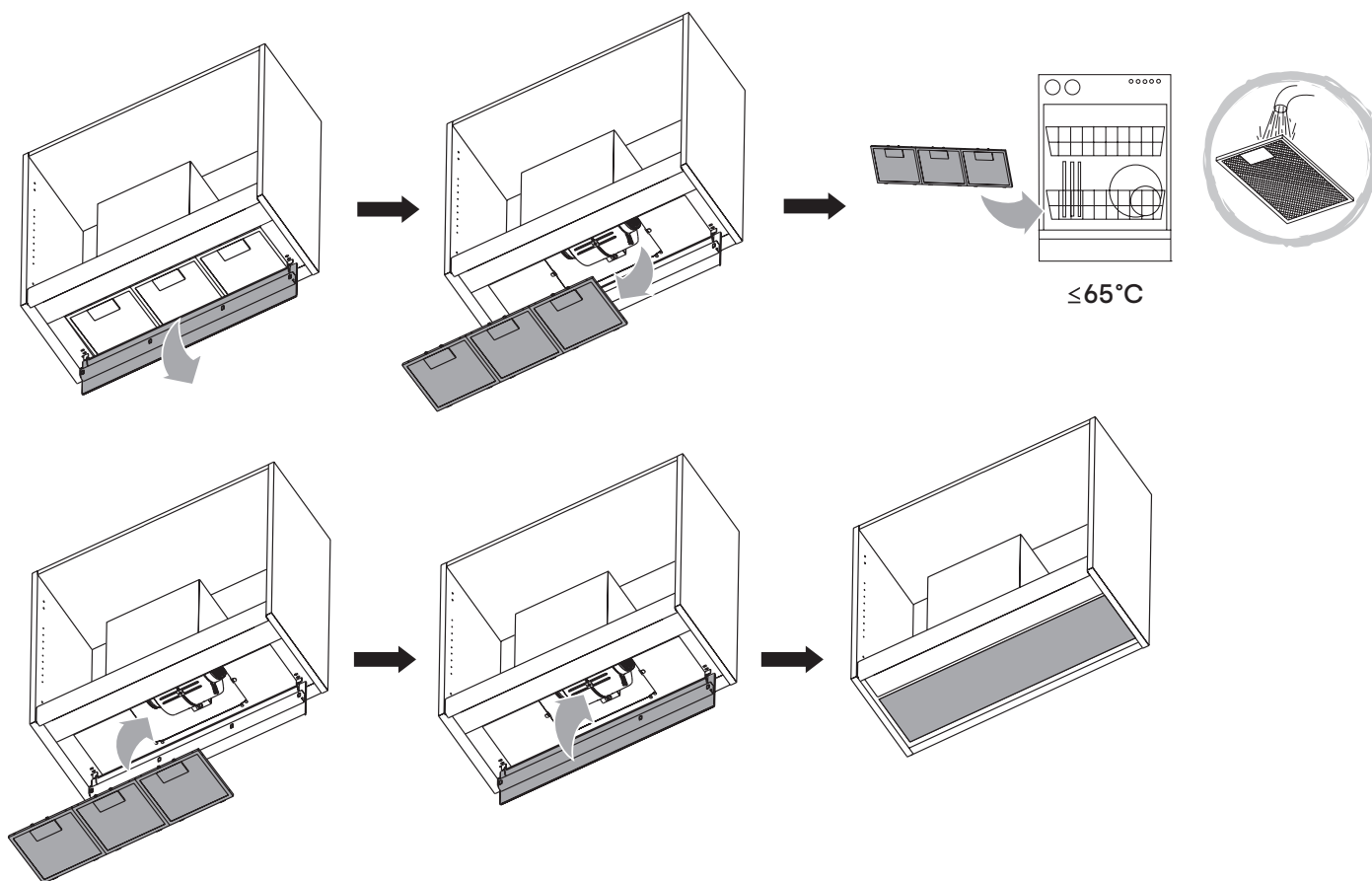

1 MONTH



If the motor is off, and after the fan has been in operation for approximately 50 hours, the display will show  and the Timer will flash red to advise you to clean the aluminium grease filters. After cleaning the filters, reset the alert by pressing the Timer icon .



WARNING: Increase the filter cleaning/replacement frequency if the hood is used for more than 2 hours a day. Always use genuine filters from the manufacturer.

03 Lamp replacement

The LED lamps in this appliance are not replaceable by the consumer. If a lamp fails, please contact the Customer Helpline at the end of Care & maintenance to arrange an engineer visit.



FR Entretien et maintenance

01 Remplacement des filtres à charbon



Remplacer les filtres à charbon tous les trois mois.

Pour remplacer les filtres à charbon :

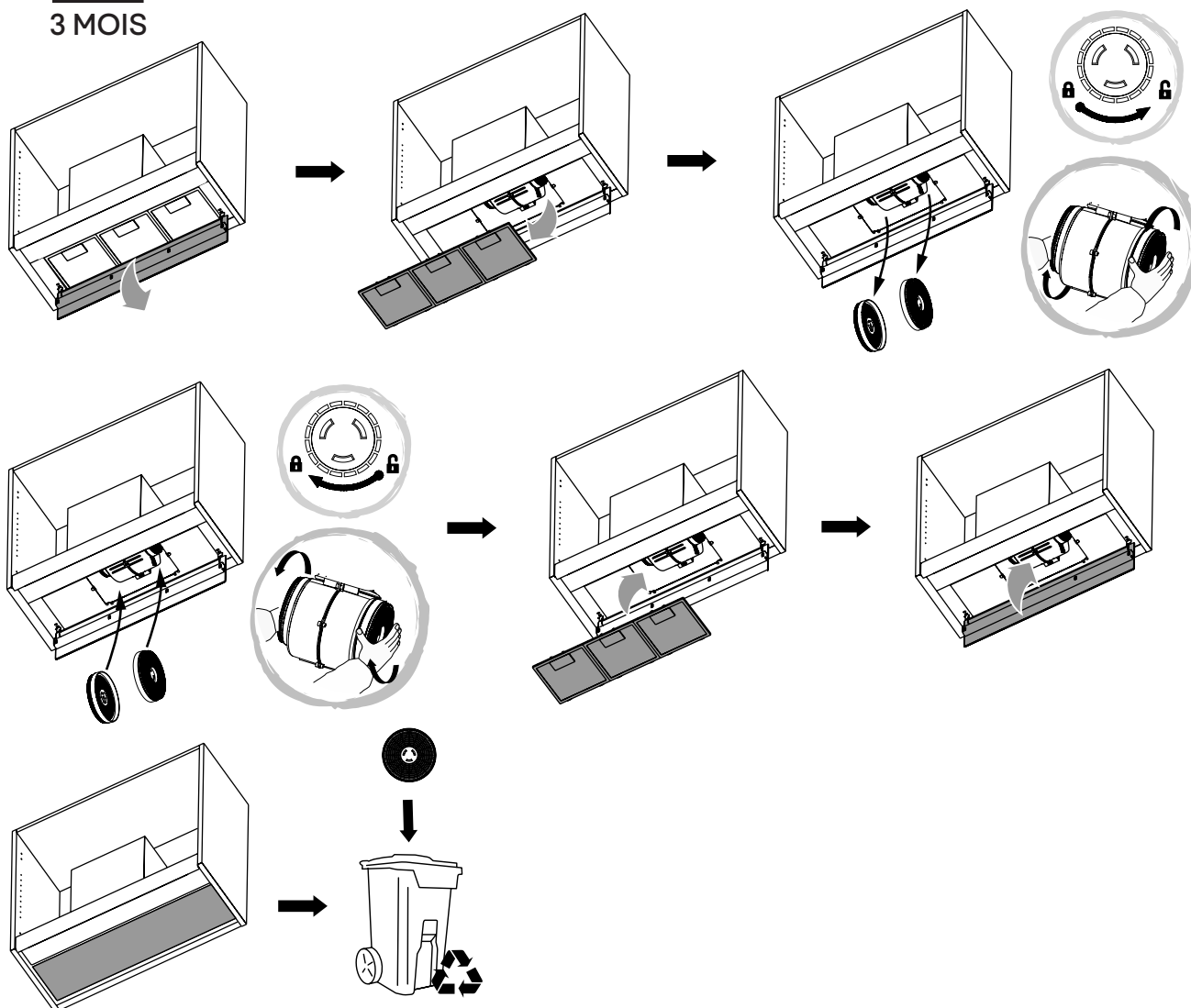
1. Tirer vers le bas le panneau de verre arrière pour l'ouvrir.
2. Retirer les filtres à graisse en aluminium.
3. Remplacer les filtres à charbon.
4. Replacer les filtres à graisse.
5. Fermer le panneau de verre arrière.



2 filtres à charbon, modèle CARBFILT 50 disponible via l'assistance téléphonique (voir la fin de la section Entretien et maintenance pour plus de détails).

Si le moteur est éteint et que le ventilateur a fonctionné pendant environ 150 heures, l'écran affiche  et la minuterie clignote de couleur bleue pour vous conseiller de remplacer les filtres à charbon. Après le remplacement des filtres, réinitialiser l'alerte en appuyant sur l'icône Timer (minuterie) .



AVERTISSEMENT : toujours couper l'alimentation électrique avant d'effectuer des travaux d'entretien sur la hotte. En cas de problème, contacter le service client.





02 Nettoyage des filtres à graisse en aluminium

Filtres en aluminium : pour éviter les incendies, bien les nettoyer une fois par mois. Retirer les deux filtres à graisse comme indiqué et les tremper dans de l'eau chaude et du détergent pendant une heure. Si vous utilisez un lave-vaisselle, placer les filtres de manière verticale pour améliorer le processus de nettoyage.

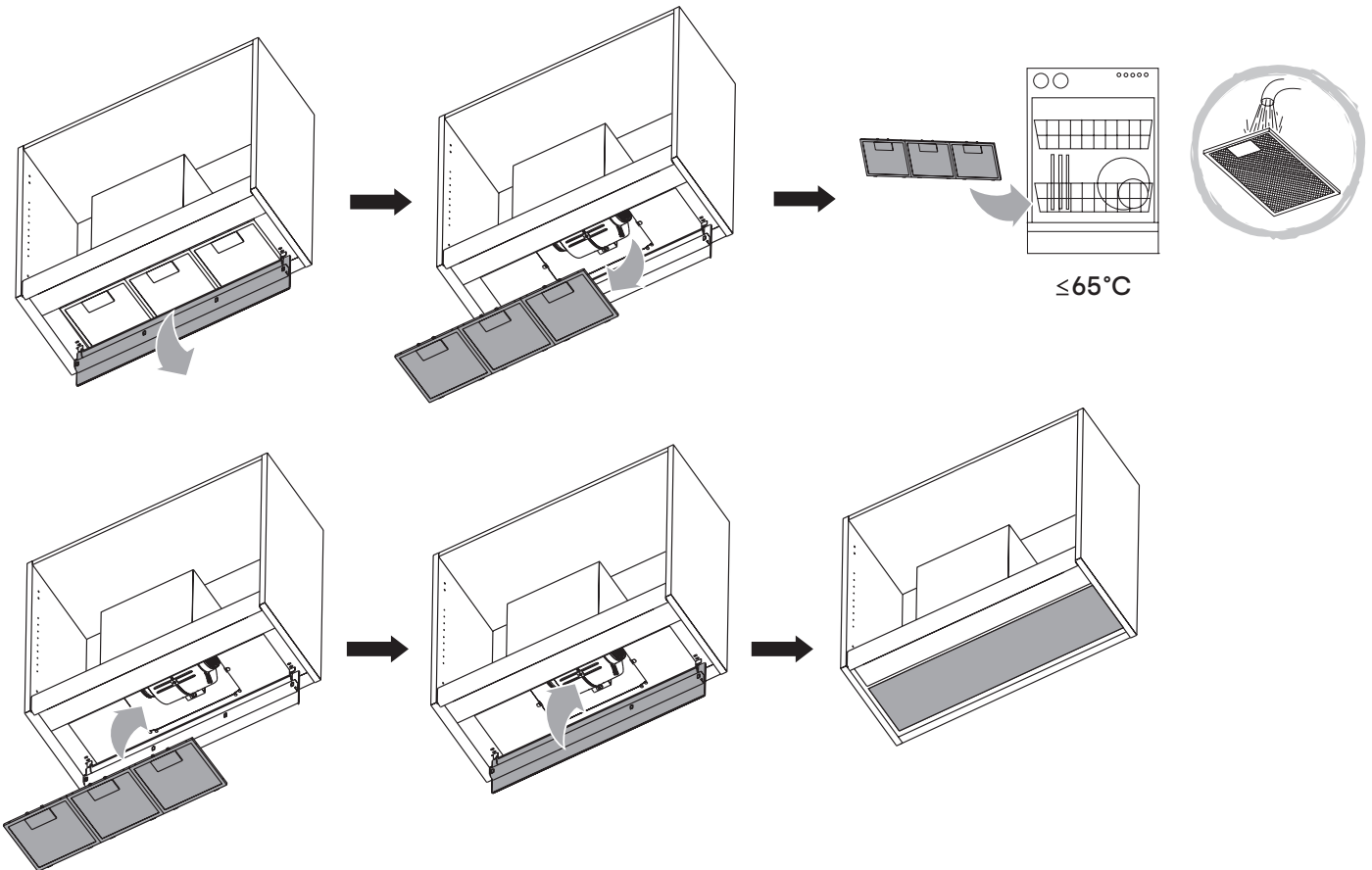

1 MOIS



Si le moteur est éteint et après une durée d'activité du ventilateur de 50 heures environ, l'écran affiche  et la minuterie clignote en rouge pour vous conseiller de nettoyer les filtres à graisse en aluminium. Après le nettoyage des filtres, réinitialiser l'alerte en appuyant sur l'icône Timer (minuterie) .



AVERTISSEMENT : augmenter la fréquence de remplacement/nettoyage des filtres si la hotte est utilisée plus de 2 heures par jour. Toujours utiliser les filtres d'origine du fabricant.

03 Remplacement des lampes

Les lampes LED de cette appareil ne peuvent pas être remplacées par le client. En cas de panne d'une lampe, contacter l'assistance téléphonique mentionnée à la fin de la section Entretien et maintenance pour organiser un rendez-vous avec un technicien.



PL Czyszczenie i konserwacja

01 Wymiana filtra węglowego

Wymieniać filtry węglowe co 3 miesiące.

Aby wymienić filtry węglowe:

1. Pociągnij tylną pokrywę szklaną w dół, aby ją otworzyć.
2. Wyjmij aluminiowe filtry odtłuszczające.
3. Wymień filtry węglowe.
4. Wymień filtry odtłuszczające.
5. Zamknij tylną pokrywę szklaną.



3 ODSTĘPIE
X MIESIĘCY

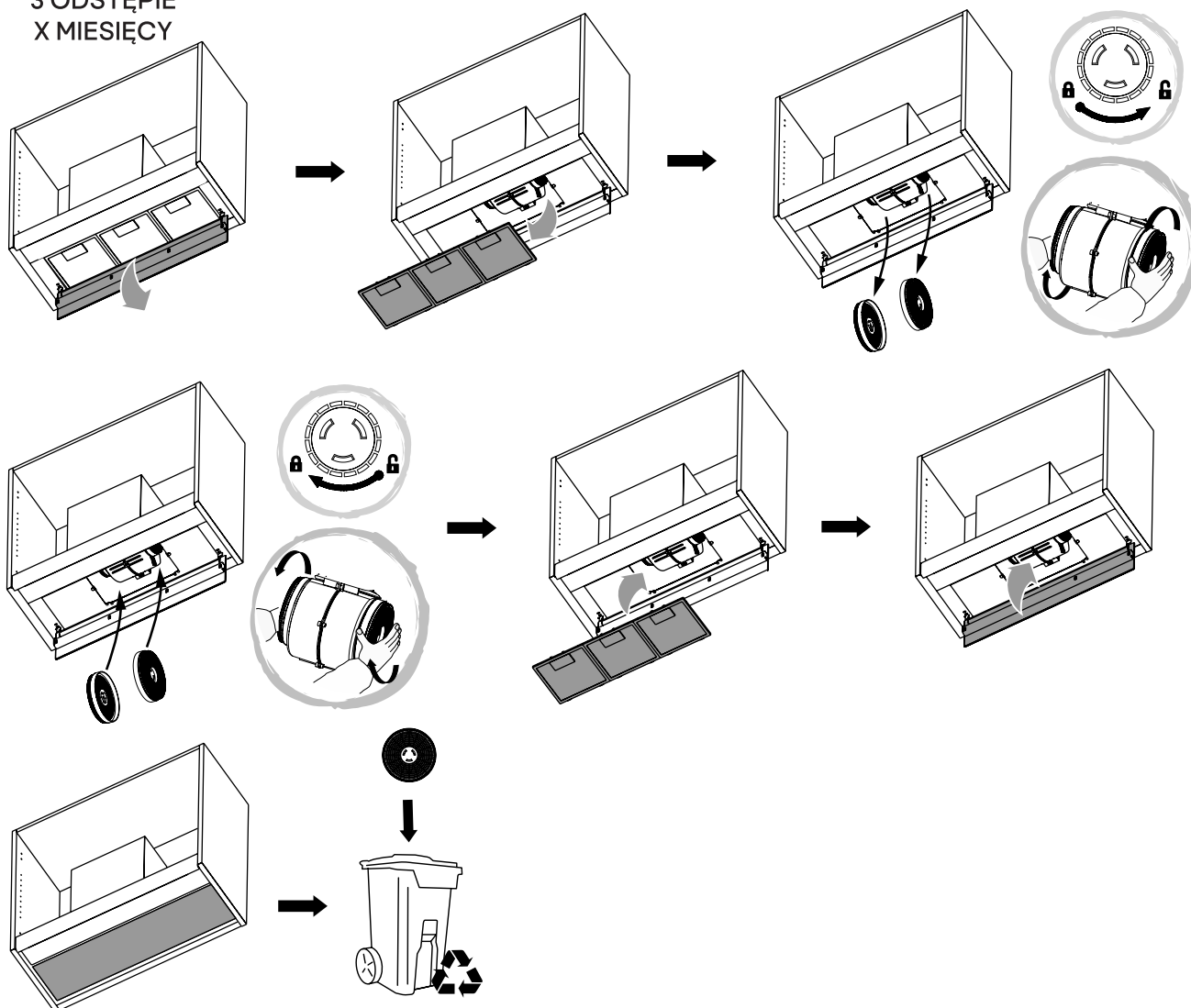

2x filtr węglowy, model CARBFILT 50, dostępny za pośrednictwem infolinii dla klientów – patrz koniec części Konserwacja i utrzymanie, aby dowiedzieć się więcej.

Jeśli silnik jest wyłączony i po upływie około 150 godzin pracy wentylatora. Na wyświetlaczu pojawi się komunikat, a timer zacznie migać na niebiesko, aby poinformować o konieczności wymiany filtrów węglowych. Po wymianie filtrów należy zresetować alarm poprzez naciśnięcie ikony timera ☹.



OSTRZEŻENIE: Przed rozpoczęciem prac konserwacyjnych przy okapie należy najpierw zawsze wyłączyć zasilanie elektryczne. W przypadku usterki skontaktować się z działem obsługi klienta.





02 Czyszczenie aluminiowego filtra odtłuszczającego

Filtry aluminiowe: aby uniknąć pożaru, należy dokładnie czyścić filtr co miesiąc. Wyjmij oba filtry odtłuszczające, jak pokazano na rysunku, i zanurz je w gorącej wodzie z detergentem na godzinę. W przypadku korzystania ze zmywarki ustawić filtry w pionie, aby poprawić proces czyszczenia.

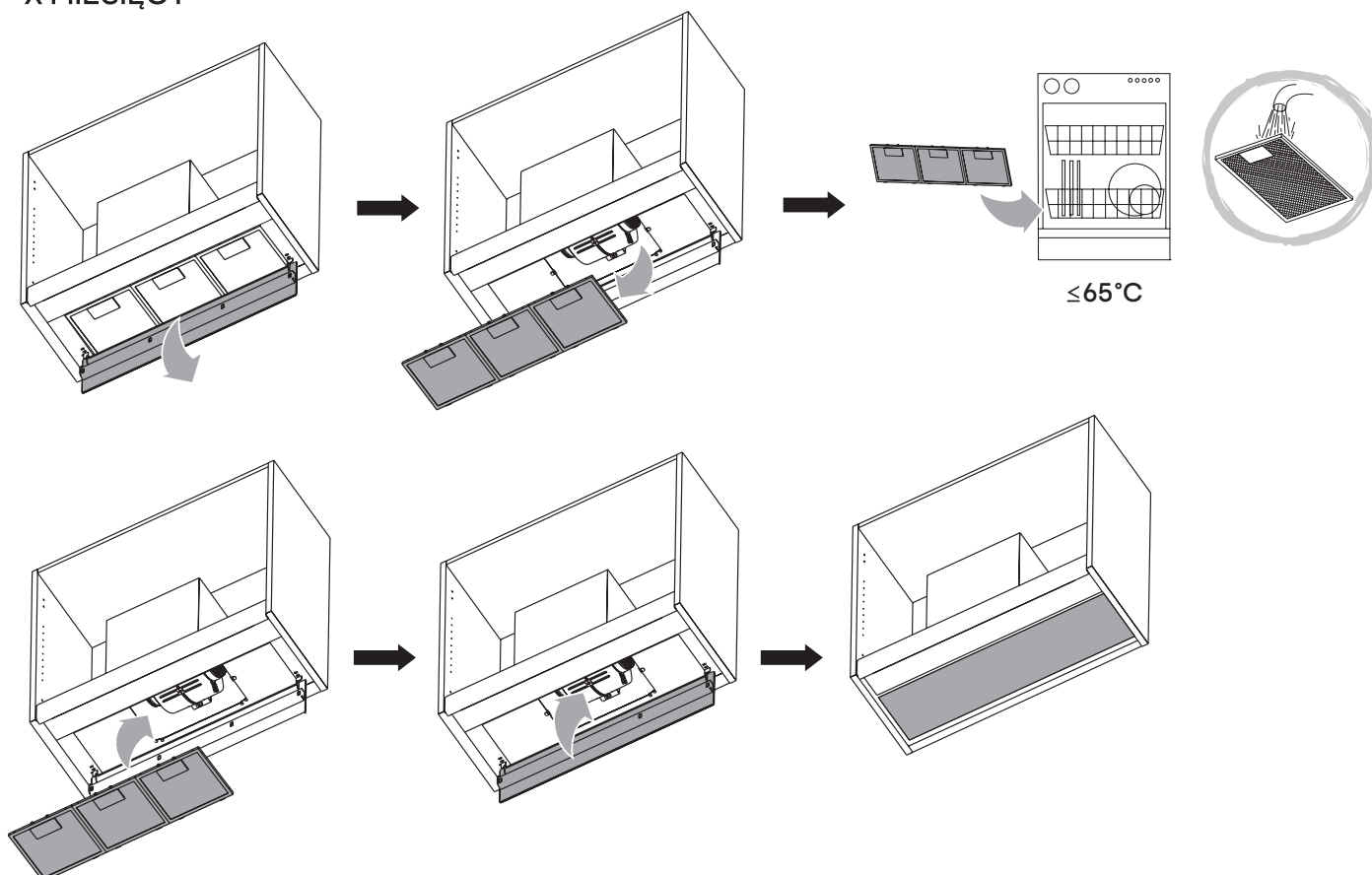

1 ODSTĘPIE
X MIESIĘCY



Po około 50 godzinach pracy wentylatora na wyświetlaczu, przy wyłączonym silniku, pojawia się wskazanie , a timer miga na czerwono, co sygnalizuje konieczność oczyszczenia aluminiowych filtrów odtłuszczających. Po wyczyszczeniu filtrów należy zresetować alarm poprzez naciśnięcie ikony timera .



OSTRZEŻENIE: Jeśli okap jest używany dłużej niż przez 2 godziny dziennie, należy zwiększyć częstotliwość czyszczenia/wymiany filtra. Zawsze używać oryginalnych filtrów od producenta.

03 Wymiana lampki

Lampki LED w urządzeniu nie są przeznaczone do samodzielnej wymiany. Jeśli lampka ulegnie awarii, należy skorzystać z infolinii dla klientów – patrz koniec części „Czyszczenie i konserwacja”.



RO Îngrijire și întreținere

01 Înlocuirea filtrului de carbon



Înlocuiți filtrele de carbon la fiecare trei luni.

Pentru înlocuirea filtrelor de carbon:

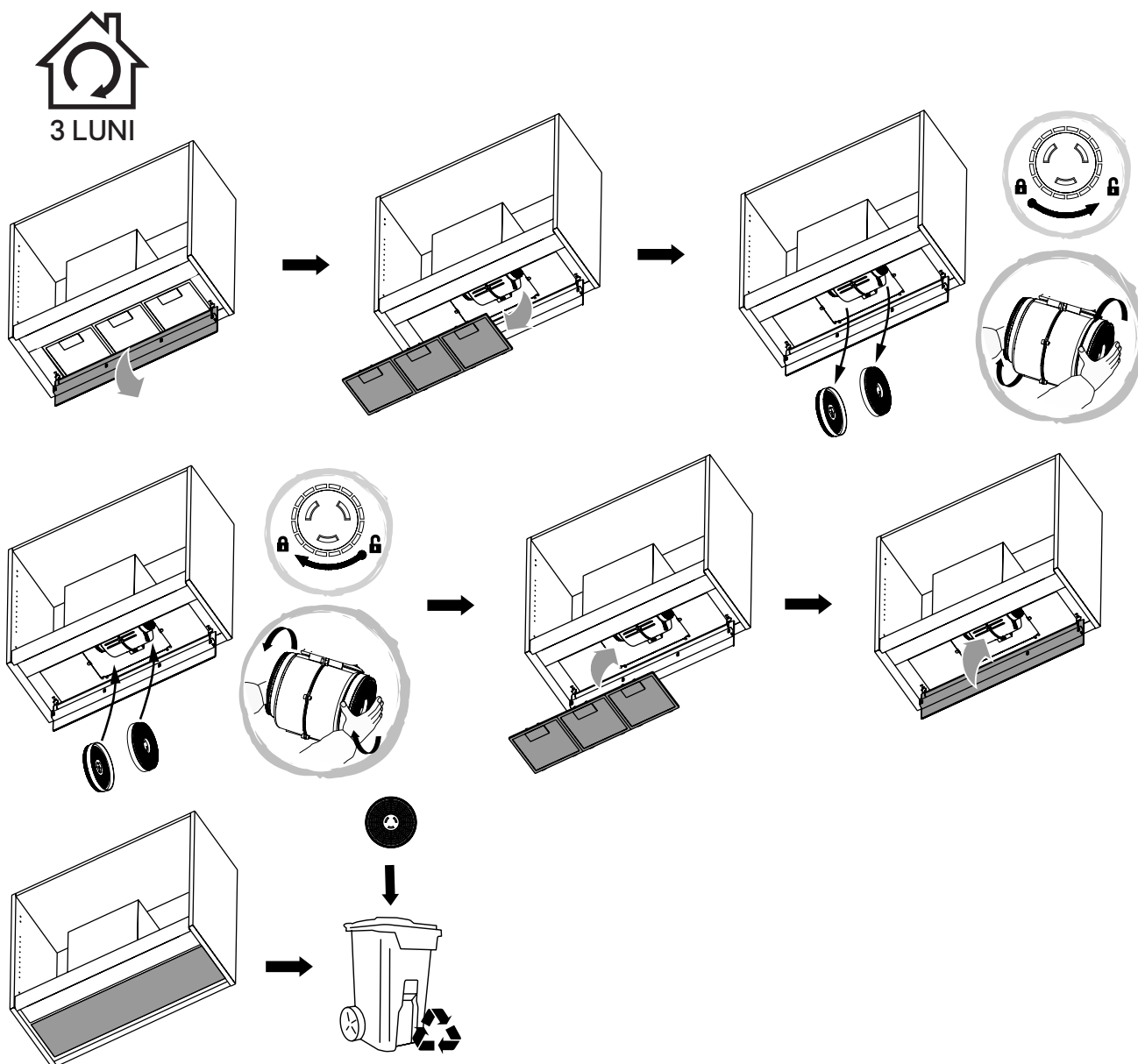
1. Trageți în jos panoul din sticlă pentru a-l deschide.
2. Scoateți filtrele din aluminiu pentru grăsime.
3. Schimbați filtrele de carbon.
4. Înlocuiți filtrele pentru grăsime.
5. Închideți panoul posterior din sticlă.



2 filtre de carbon, model: CARBFILT 50, disponibile prin linia de asistență clienți - consultați finalul secțiunii Îngrijire și întreținere pentru detalii.

Dacă motorul este oprit și ventilatorul a funcționat timp de aproximativ 150 de ore. Pe afișaj va apărea , iar Temporizatorul va lumina intermitent în culoarea albastră, pentru a vă recomanda să înlocuiți filtrele din carbon. După înlocuirea filtrelor, reșetați alerta apăsând pictograma Temporizator .



AVERTISMENT: Deconectați întotdeauna alimentarea electrică înainte de a efectua lucrări de întreținere la hotă. În caz de defecțiune, contactați Serviciul de asistență clienți.





02 Curățarea filtrului de grăsime din aluminiu

Filtre din aluminiu: Pentru evitarea incendiilor, curățați bine o dată pe lună. Îndepărtați ambele filtre conform instrucțiunilor și înmuiați-le în apă fierbinte cu detergent timp de o oră. Dacă folosiți o mașină de spălat vase, poziționați filtrele vertical pentru îmbunătățirea procesului de curățare.

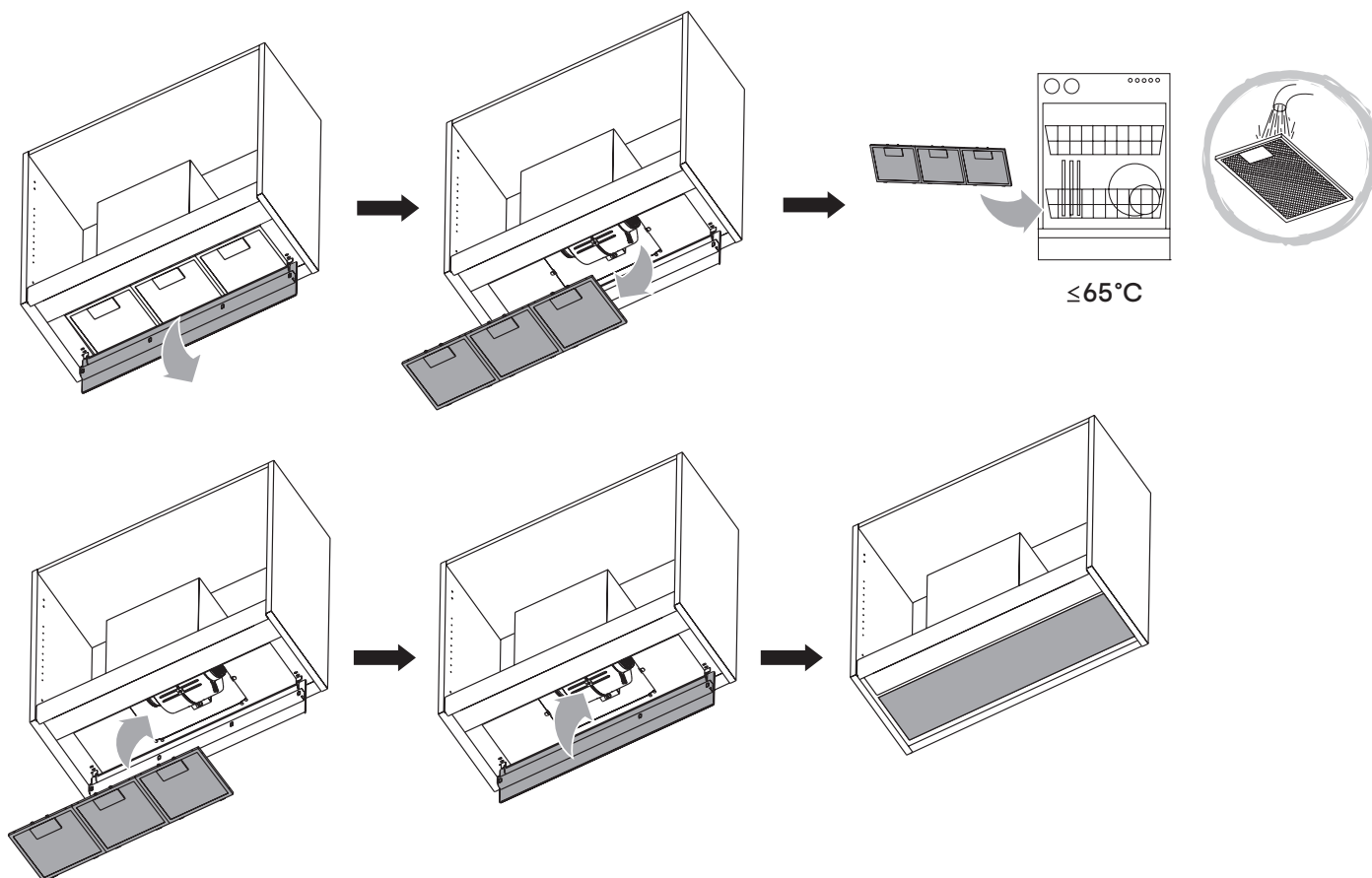

1 LUNI



Dacă motorul este oprit și ventilatorul a funcționat timp de aproximativ 50 de ore, pe afișaj va apărea , iar Temporizatorul va lumina intermitent în culoarea roșie, pentru a vă recomanda să curățați de grăsime filtrele de aluminiu. După curățarea filtrelor, reșetați alerta apăsând pictograma Temporizator .



AVERTISMENT: Curățați/înlocuiți filtrele din hotă la intervale mai mici dacă aceasta este folosită mai mult de 2 ore pe zi. Folosiți întotdeauna filtre originale de la producător.

03 Înlocuirea becului

Lămpile LED din acest aparat nu pot fi înlocuite de client. Dacă o lampă se arde, contactați Linia de Asistență Clienți specificată la finalul secțiunii Îngrijire și Întreținere, pentru a stabili o vizită a unui inginer.

Manufacturer • Fabricant • Producent • Producător:

Kingfisher International Products Limited,
3 Sheldon Square, London, W2 6PX,
United Kingdom
www.kingfisher.com/products
Kingfisher International Products B.V.
Rapenburgerstraat 175E
1011 VM Amsterdam
The Netherlands

EN Distributor:

B&Q plc, Chandlers Ford, Hants, SO53 3LE
United Kingdom
www.diy.com

Screwfix Direct Limited, Trade House,
Mead Avenue, Yeovil, BA22 8RT,
United Kingdom
www.screwfix.com

**To view instruction manuals online,
visit www.kingfisher.com/products**

Customer Helpline (Freephone)
UK 0800 324 7818 uk@kingfisherservice.com
Eire 1800 932 230 eire@kingfisherservice.com

FR Distributeur:

Castorama France C.S. 50101 Templemars 59637
Wattignies CEDEX
www.castorama.fr

BRICO DÉPÔT 30-32 rue de la Tourelle
91310 Longpont-sur-Orge France
www.bricodepot.com

**Pour consulter les manuels d'instructions en ligne,
rendez-vous sur le site www.kingfisher.com/products**

Assistance téléphonique (sans frais) :
0800 733 030 france@kingfisherservice.com

PL Dystrybutor:

Castorama Polska Sp. z o.o. ul.
Krakowiaków 78, 02-255 Warszawa
www.castorama.pl

**Aby zapoznać się z instrukcją obsługi online,
odwiedź stronę www.kingfisher.com/products**

Infolinia dla klientów (bezpłatna)
800 121 2222 poland@kingfisherservice.com

RO Distribuitor:

SC Bricostore România SA
Calea Giulești 1-3, Sector 6,
București, România
www.bricodepot.ro

Praktiker Romania S.A.
Splaiul Independenței, nr 319 L și M, Clădirea
Bruxelles, etaj 1, Sector 6, RO-060044,
București, România
Tel: +40 021 2047100
www.praktiker.ro

**Pentru a consulta manualele de instrucțiuni online,
vizitați www.kingfisher.com/products**

Asistență clienți (apel gratuit):
0800 895 099 romania@kingfisherservice.com